

JAPANESE RESPECT LANGUAGE

When, Why, and How to Use It Successfully

P. G. O'NEILL

TUTTLE PUBLISHING
Tokyo • Rutland, Vermont • Singapore

<5.> DE WA G _____. Tsukimashite, Jimukyoku Shomuka ni, Shimoyama Keiko to iu hito ga arimasu. Kono mae <6.> ____ -SHOKAI _____ jousei desu. Sono kata ni <7.> ____ -YOKEN o o-hanashi kudasareba, sassoku dengon shite kuremasu.

Thank you for your news. I am sorry that you were unable to accomplish your business even though you kindly contacted the research institute. Since I am concentrating upon investigations and private research, I am not an official member of the research institute. In this connection, there is, in the General Affairs Section of the Administration Department, someone called Keiko Shimoyama. She is the woman I introduced to you earlier. If you would kindly tell her of any business you might have, she will pass it on to me right away.

その方法をご利用 <8.> _____. 詳しくは <9.> _____ 会い _____ 時に <10.> _____ 話 _____。

Sono hōhō o go-riyō <8.> K _____ Kuwashiku wa <9.> ____ -AI _____ toki ni <10.> ____ -HANASHI M _____.

Please use that approach. I will go into details when I see you (next).

さて、ご用向きのお答えを <11.> _____ ます。私、本日研究所の田中先生と打ち合わせました。彼はどのような目的で <12.> _____ に _____ かと言って <13.> _____ が、せっかく <14.> _____ のでしたら研究所の皆 <15.> _____ がおりました方が

<16.> _____ よろしいのではないかと <17.> _____、四月三十日一時ごろが最適との返事を <18.> _____ <19.> _____。

Sate, go-yō muki no o o-kotae o <11.> M _____ masu. Watakushi, honjitsu kenkyūjo no Tanaka sensei to uchiawasemashita. Kare wa dono yō na mokuteki <12.> DE _____ NI _____ ka to itte <13.> O _____ ga, sekkaku <14.> K _____ no deshitara kenkyūjo no <15.> MINA- _____ ga orimashita hō ga <16.> _____ -YOROSHII no de wa nai ka to <17.> I _____, Shigatsu Sanjū-nichi ichiji gogo ga saiteki to no henji o <18.> K _____ <19.> -M _____.

Well now, I will give you an answer about that matter of yours. I have today arranged things with Professor Tanaka of the research institute. He wondered what kind of aim you had in mind, and saying that it might be better if all the institute people were present if you were going to the trouble of calling, was good enough to reply that 1 o'clock on the afternoon of 30th April would be most convenient.

山住さんのほうは <20.> _____ ですか。ご計画に急な変化がありましたらお知らせ <21.> _____。一応私はその日の十二時三十分に東京駅の十三番線ホームで <22.> _____ 待ち _____ ます。

Yamazumi-san no hō wa <20.> I _____ desu ka. Go-keikaku ni kyū na henka ga arimashitara o-shirase <21.> K _____. Ichio watakushi wa sono hi no jūnji sanjuppun ni Tōkyō eki no jūsan bansen hōmu de <22.> _____ -MACHI I _____ masu.

How will that be for you, Mr. Yamazumi? If there should be any sudden change in your plans, please let me know. Tentatively, I shall wait for you at 12:30 on that day on Platform 13 at Tokyo Station.

また、その後、いろいろと <23.> _____ 研究 _____ ことと <24.> _____。私も二三日前まで研究やらアルバイトやらで忙しく日々を過ごしておりましたが、今は少し落ち着いております。

Mata sono go, iroiro to <23.> _____ -KENKYŪ S _____ koto to <24.> Z _____ . Watakushi mo nisannichi mae made kenkyū yara arubaito yara de isogashiku hibi o sugoshite orimashita ga, ima wa sukoshi ochitsuite orimasu.

Since I saw you last, you have carried on your research in various ways, I suppose. I too had been having a busy time until a few days ago, what with my research and my spare-time work, but I am a bit more settled now.

それでは乱筆で <25.> _____ が、よろしくご了承下さい。

Sore de wa ranpitsu <25.> DE G _____ ga, yoroshiku go-ryōshō kudasai.

Well now, this is written very untidily, but I hope you will make allowances.

さようなら
Sayōnara,
Goodbye,

四月二十日
Shigatsu hatsuka
20th April

山本静夫
Yamamoto Shizuo
Shizuo Yamamoto

山住健二さま
Yamazumi Keiji-sama
Mr. Keiji Yamazumi

Answer Key

1. お(便り) O(-TAYORI) (P 2 便り tayori) page 31
2. 存じます ZONJIMASU (Df 2 思います omoimasu) page 78
3. 私 WATAKUSHI (P 2 私 watashi) page 27
4. おります ORIMASU (Df 2 いる iru) page 117
5. (では) ございません (DE WA) GOZAIMASEN (Df 2 ではありません de wa arimasen) page 117
6. ご(紹介)いたした GO(-SHŌKAI) ITASHITA (Dp 2 紹介した shōkai shita) page 77
7. ご(用件) GO(-YŌKEN) (P 2 用件 yōken) page 31
8. ください KUDASAI (4Hi 2 ください kudasai) page 134
9. お(会)いたした O(-AI) ITASHITA (Dp 2 あった atta) page 83
10. お(話)申し上げます O(-HANASHI) MŌSHIAGEMASU (Df 2 話します hanashimas) page 116
11. 申し上げ MŌSHIAGE (Dp 2 言い(ます) ii(masu)) page 78
12. (で)おいで(に)なる (DE) OIDE (NI) NARU (H 2 (or 3 = 2) だ da) page 54

13. おりました **ORIMASHITA** (Df 2 いました **imashita**)
page 117
14. 来られる **KORARERU** (H 2 (or 3 = 2) くる **kuru**)
pages 63-64
15. (皆)さん (**MINA**)-**SAN** (P 3 皆さん **mina-san**) page 19
16. お(よろしい) **O(-YOROSHII)** (P 2 (or 3 = 2) よろしい/いい **yoroshii/ii**) pages 139-140
17. 言われて **IWARETE** (H 3 いて **itte**) pages 63-64
18. ください **KUDASAI** (H 3 くれ **kure-**) page 54
19. ました **MASHITA** (423; Df 2 ました **-mashita**) page 115
20. いかが **IKAGA** (P 2 どう **dō**) page 27
21. ください **KUDASAI** (HI 2 ください **kudasai**) page 134
22. お(待ち)いたし **O(-MACHI) ITASHI** (Dp 2 待っています) **matte i(masu)**) page 76
23. ご(研究)された **GO(-KENKYŪ) SARETA** (H 2 研究した **kenkyū shita**) pages 63-64
24. 存じます **ZONJIMASU** (Df 2 思います **omoimasu**)
page 116
25. (で)ございます (**DE**) **GOZAIMASU** (Df 2 です **desu**)
page 117

Practice Text 3

Letter from a publishing firm to a university teacher.

向寒の候、博士にはお障りなく <1.> _____ 活躍の御こと _____ 慶び <2.> _____。

Kōkan no migiri, hakase ni wa o-sawari naku <1.> _____
-KATSUYAKU no on-koto <2.> _____ **-YOROKOBI** _____。

Now that the cold weather is upon us, I am happy that you, Dr. Honda, should be continuing your activities without hindrance.

小社は歴史関係の図書を発行いたしております出版社で <3.> _____。早稲田大学の井上元幸先生のもとで歴史研究を <4.> _____ ために上京 <5.> _____ ましたことを <6.> _____ ました。ぜひ、お話を聞かせて <7.> _____ 対談として小社発行の月刊史学時報に記事を掲載 <8.> _____ <9.> _____ <10.> _____。小社の社長武田次郎が <11.> _____ 話の <12.> _____ 相手をさせていただき、編集部の方が筆記 <13.> _____ ます。掲載は二月号で <14.> _____ が本年十二月中に原稿をまとめておく予定で <15.> _____。

Shōsha wa rekishi kankei no tosho o hakkō itashite orimasu shuppansha <3.> DE _____. Waseda Daigaku no Inoue Motoyuki sensei no moto de rekishi kenkyū o <4.> N _____ tame ni jōkyō <5.> S _____ mashita koto o <6.> U _____-mashita. Zehi o-hanashi o kikasete <7.> I _____ taidan to shite shōsha hakkō no gekkan Shigaku Jihō ni kiji o keisai <8.> I _____ <9.> Z _____ <10.> O _____. Shōsha no shachō Takeda Jirō ga <11.> _____-HANASHI no <12.> _____-AITE o sasete itadaki, henshūbu no mono ga hikki <13.> I _____ masu. Keisai wa Nigatsu-gō <14.> DE _____ ga honnen jūnigatsu-chū ni genkō o matomete oku yotei <15.> DE _____.

Our company is a publishing company which brings out books on history. Since we heard that you have come up to Tokyo to do some historical research under Professor Motoyuki Inoue of Waseda University, we should like to have you talk to us about various things and to carry an article in the form of interview, in the monthly Historical Review published by our company. The head of our company, Jirō Takeda, would (like you to allow him to) be the person to talk with you, and someone from our editorial section will take notes. Publication will be in the February number; we plan to put the draft together in readiness during December this year.

ご多用のところ誠に恐縮に <16.> _____ が、お手すき時間の候補をお挙げ <17.> _____ <18.> _____。その中から、対談の日取りを決めたいと存じます。場所も <19.> _____ 指定 <20.> _____ なお結構でございます。勝手を <21.> _____ ますが年末は何かと

忙しくなりますので二十五日ごろまでにお願ひできれば幸ひでございます。

Go-tayō no tokoro makoto ni kyōshuku ni <16.> Z _____ ga, o-tesuki no hi to jikan no kōho o o-age <17.> I _____ <18.> G _____. Sono naka kara, taidan no hidori o kimetai to zonjimasu. Basho mo <19.> _____-SHITEI <20.> K _____ nao kekkō de gozaimasu. Katte o <21.> M _____ masu ga nenmatsu wa nanika to isogashiku narimasu no de nijūgo-nichi goro made ni o-negai dekireba saiwai de gozaimasu.

We are indeed reluctant (to ask you) when you are so busy, but we would like you to offer two or three possibilities of days and times when you are free. We should then like to decide the date of the interview from among these. It would be even better if you would also be good enough to indicate a place. We speak (to suit) our own convenience but, since the end of the year becomes very busy one way and another, we would be happy if our request could be dealt with by the 25th.

右井上先生からお聞き及びかもしれませんが何とぞよろしく <22.> _____ 願ひ _____。

Migi Inoue sensei kara o-kikioyobi ka mo shiremasen ga nanitozo yoroshiku <22.> _____-NEGAI _____.

You may have already heard about the above matter from Professor Inoue, but we (should like to) ask for your kind help in this.

返信ハガキを同封 <23.> _____ ます。ご返事を <24.> _____ 待ち _____ おります。

Henshin hagaki o dōfū <23.> I _____ masu. Go-henji o
<24.> _____-MACHI _____ orimasu.

We enclose a postcard for reply. We are looking forward to
(receiving) your answer.

敬具

Keigu,

With respect,

史学時報編集部

Shigaku Jihō henshūbu

Editorial Section, Historical Review

十一月十九日

Jūichigatsu jūkunichi

19th November

岩本勇

Iwamoto Isamu

Isamu Iwamoto

本多洋様

Honda Hiroshi-sama

Mr. Hiroshi Honda

Answer Key

1. ご(活躍) **GO(-KATSUYAKU)** (P 2 活躍 *katsuyaku*)
page 31
2. お(慶び)申し上げます **O(-YOROKOBI) MŌSHIAGE-**
MASU (Df 2 よろこんでいます *yorokonde imasu*) *page*
116
3. (で) ございます **(DE) GOZAIMASU** (Df 2 です *desu*)
page 117

4. なさる **NASARU** (H 2 する *suru*) *page 54*
5. され **SARE** (H 2 し(た) *shi(ta)*) *pages 63-64*
6. 伺い **UKAGAI** (Dp 3 聞き(ました) *kiki(mashita)*) *page*
83
7. いただき **ITADAKI** (Dp 2 もらい *morai*) *page 78*
8. いたしたく **ITASHITAKU** (Dp 2 したく *shitaku*) *page*
78
9. 存じて **ZONJITE** (Df 2 思っ *omotte*) *page 116*
10. おります **ORIMASU** (Df 2 います *imasu*) *page 117*
11. お(話) **O(-HANASHI)** (P 2 話 *hanashi*) *page 31*
12. お(相手) **O(-AITE)** (P 2 相手 *aite*) *page 31*
13. いたし **ITASHI** (Dp 2 し(ます) *shi(masu)*) *page 78*
14. (で) ございます **(DE) GOZAIMASU** (Df 2 です *desu*)
page 116
15. (で) ございます **(DE) GOZAIMASU** (Df 2 です *desu*)
page 116
16. 存じます **ZONJIMASU** (Df 2 思います *omoimasu*) *page*
116
17. いただきとう **ITADAKITŌ** (Dp 2 もらいたい *moritai*)
page 78, page 141
18. ございます **GOZAIMASU** (です *desu*) *page 117*
19. ご(指定) **GO(-SHITEI)** (P 2 指定 *shitei*) *page 31*
20. くだされば **KUDASAREBA** (H 2 くれれば *kurereba*)
page 54
21. 申し **MŌSHI** (Dp 2 言います *ii(masu)*) *page 78*
22. お(願)い申し上げます **O(-NEGAI) MŌSHIAGEMASU**
(Df 2 願います *negaimasu*) *page 116*
23. いたし **ITASHI** (Dp 2 し(ます) *shi(masu)*) *page 78*
24. お(待)ち申し上げ **O(-MACHI) MŌSHIAGETE**
(Df 2 待つ *matte*) *page 116*

Practice Text 4

Excerpt from a play; a conversation between two women: Keiko, age 24, and Midori, age 40.

Keiko: <1.> _____ の母は生きて <2.> _____
し、ともかくあなたがここに <3.> _____ 住み
に _____ にことについての条件をひと通り
<4.> _____ 聞きに _____ くださいます。

<1.> **W** _____ **no haha wa ikite** <2.> **O** _____
shi, tomokaku anata ga koko ni <3.> _____ **-SUMI**
NI _____ **koto ni tsuite no jōken o hitotōri**
<4.> _____ **-KIKI NI** _____ **kudasaimasu.**

My mother isn't alive and, be that as it may, will you
listen briefly to the conditions about your living here?

Midori: 伺いましょう。

<5.> **U** _____ **mashō.**

Let me hear them.

Keiko: まず一人暮らしを <6.> _____ こと。それさ
え <7.> _____ 守りに _____ ほかは何をなさ

ろうとご自由に。それからもうひとつ。菊池は今
後あなたに <8.> _____ 会い _____ だそうで
す—何か起こらない限りは。これでおわかりに
なりました。菊池があなたにここで <9.> _____
暮らしに _____ <10.> _____ と思ってい
る訳はいまさら <11.> _____ 説明 _____ までも
<12.> _____ わね。もしいますぐ <13.> _____
返事が <14.> _____ ようでしたら...

Mazu hitori-gurashi o <6.> **N** _____ **koto.**

Sore sae <7.> _____ **-MAMORI NI N** _____

hoka wa nani o nasarō to go-jiyū ni. Sore kara mō
hitotsu. Kikuchi wa kongo anata ni <8.> _____

-AI S _____ **da sō desu — nani ka okoranai**

kagiri wa. Kore de o-wakari ni narimashite. Kikuchi
ga anata ni koko de <9.> _____ **-KURASHI NI**

_____ <10.> **I** _____ **to omotte iru wake wa**

imasara <11.> _____ **-SETSUMEI S** _____

made mo <12.> **G** _____ **wa ne. Moshi ima**

sugu <13.> _____ **-HENJI ga** <14.> **I** _____

yō deshitara, ...

First of all, there's one to the effect that you will live
alone. If only you observe that, you are free to do what
you like in other respects. Then there's one more. Kikuchi
says that he'll never see you again—insofar as nothing
out of the ordinary occurs.

Do you understand it now? The reason why Kikuchi
(feels he) wants you to live here, there's no need for me
to explain at this stage, is there? If it seems that we can
have your answer right away, ...

Answer Key

1. 私 **WATAKUSHI** (P 2 私 *watashi*) *page 27*
2. おりません **ORIMASEN** (Df 2 いません *imasen*)
page 117
3. お(住みに)なる **O(-SUMI NI) NARU** (H 2 住む *sumu*)
pages 52-53
4. お(聞きに)なって **O(-KIKI NI) NATTE** (H 2 聞いて
kiite) *pages 52-53*
5. 伺い **UKAGAI** (Dp 2 聞き(ましょう) *kiki(mashō)*)
page 83
6. なさる **NASARU** (H 2 する *suru*) *page 54*
7. お(守りに)なれば **O(-MAMORI NI) NAREBA** (H 2
守れば *mamoreba*) *pages 52-53*
8. お(会い)しないん **O(-AI) SHINAIN'** (Dp 2 会わないん
awanain') *page 83*
9. お(暮らしに)なって **O(-KURASHI NI) NATTE** (H 2
暮らして *kurashite*) *pages 52-53*
10. いただきたい **ITADAKITAI** (Dp 2 もらいたい *moraitai*)
page 78
11. ご(説明)する **GO(-SETSUMEI) SURU** (Dp 2 説明する
setsumeisu) *page 81*
12. ございません **GOZAIMASEN** (Df 2 ありません *arimasen*)
page 117
13. ご(返事) **GO(-HENJI)** (P 2 返事 *henji*) *page 31*
14. いただける **ITADAKERU** (Dp 2 もらう *moraeru*)
page 78

Review Exam

When you are satisfied that you understand all the Practice Readings and the respect forms in them, try the below exam.

Change the below into polite/respectful/honorific words.

A. Sentences

1. Kore wa watakushi no kodomo (**desu**).
2. Massugu (**iku**) to, hashi ga arimasu.
3. Hashimoto-san wa nani mo (**iwanakatta to omoimasu**).
4. Moshi moshi! Kasa o (**wasure mashita**) yo!
5. Chotto (**tazunemasu**).
6. O-kyaku-sama ga (**mietan'**) desu ga.
7. Ano kata ni sō (**ittan'**) desu kara daijōbu deshō.
8. Dōzo, kochira e (**kite**) kudasai.
9. De wa, watakushi wa shachō-san to (**sōdan shitai**) to omoimasu.
10. Ee, watashi wa sono tsumori (**de imasu**).

B. Letter

O-tegami tashika ni **11. (uketori mashita)**. Anata wa o-isogashii no desu kara, o-shigoto no **12. (aru)** toki wa dō ka nani mo **13. (iwanakute)** mo kamaimasen.

Jūgonichi ni Hiyoshi-sai ni mairimasu ga **14. (tsugō)** ga o-yoroshikereba irashite kudasai-**15. (masu** [imperative]). Kesshite go-muri o **16. (shi)** masen yō ni **17. (negai masu)**. Gakkō no matsuri desu kara tsumaranai to omoimasu keredo, demo watakushi wa ikanakereba naranai no desu. Moshi ka o-shigoto ga **18. (arimashita)** naraba go-enryo naku sochira o o-sumase ni natte **19. (kudasaru** [imperative])-mase. Mata moshi go-tsugō ga **20. (yoroshii)** kereba, Tōyoko-sen no Hiyoshi eki no kaisatsuguchi o deta tokoro de gogo niiji ni o-machi mōshiagete orimasu. Nijihan-goro ni natte **21. (konai)**kereba go-tsugō ga o-warui mono to omotte **22. (imasu)**.

Migi tori-isogi **23. (tsūchi shimasu)**.

Sangatsu yokka

Takahashi Fumiko

Iwai Akira-sama

Answer Key

A.

1. **de gozaimasu** でございます
2. **ikareru** 行かれる
3. **ossharanakatta to zonjimasu** おっしゃらなかったと存じます
4. **o-wasure ni narimashita** お忘れになりました
5. **o-tazune shimasu** おたずねします
6. **o-mie ni nattan'** お見えになったん
7. **mōshitan'** 申したん
8. **irashite** いらして
9. **go-sōdan shitai** ご相談して
10. **de orimasu** しております

B.

11. **itadakimashita** いただきました
12. **gozaimasu** ございます
13. **ossharanakute** おっしゃらなくて
14. **go-tsugō** ご都合
15. **mase** ませ
16. **nasai** なさい
17. **o-negai mōshiagemasu** お願い申し上げます
18. **gozaimashita** ございました
19. **kudasai** ください
20. **o-yoroshi** およろしい
21. **oide ni naranakereba** お出でにならなければ
22. **mairimasu** 参ります
23. **go-tsūchi mōshiagemasu** ご通知申し上げます

APPENDIX 1

Standard Situation Diagrams

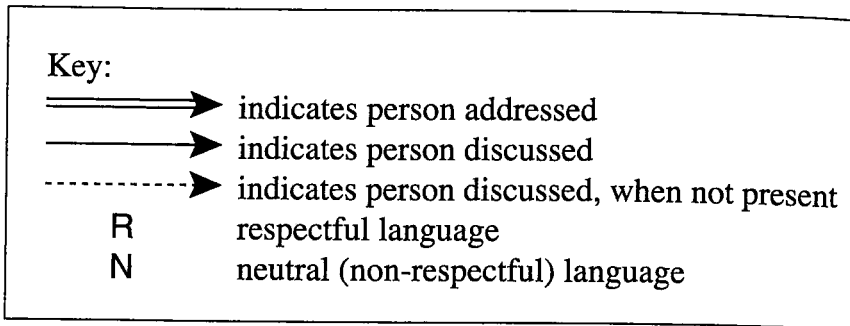

1. First-person Situations

Situations in which the person addressed (Ai), addressed and discussed (Aii), or discussed (B & C), is associated with the 1st person.

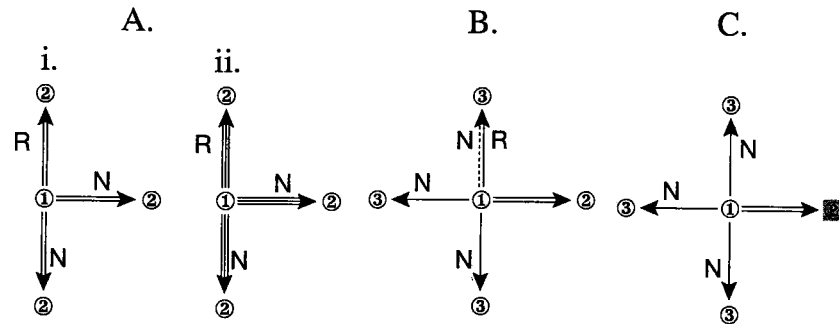

2. Second-person Situations

Situations in which the person addressed (Di), addressed and discussed (Dii), or discussed (E), is or is associated with a 2nd person unconnected with the speaker.

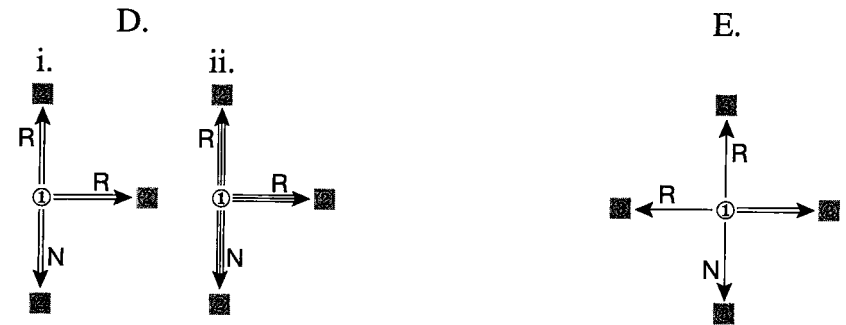

3. Third-person Situations

Situations in which the person discussed is a 3rd person unconnected with either the 1st or 2nd persons.

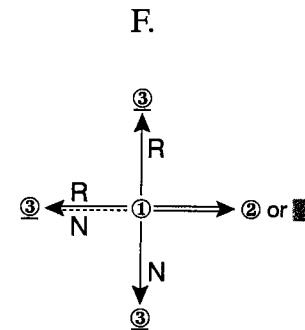

APPENDIX 2

Polite and Respectful Words

Words in the first two columns with the same meaning have been arranged in an ascending order of respect or formality. The first column contains words of widely differing connotations; but to give some idea of their usage, words used only in brusque or very informal speech have been put in parentheses, for example, (お前 **omae**), and words which, though essentially respectful, are commonly used in neutral-level speech, have been put in square brackets, for example, [あなた **anata**].

Neutral (Non-Respectful)	Polite/Respectful	Meaning
anata, omae, kimi あなた、お前、君	anata, anata-sama あなた、あなた様	you
ane 姉	nēsan², o-nēsan/ sama^{1,2} 姉さん、 お姉さん/様	elder sister
ani 兄	niisan², o-niisan^{1,2} 兄さん、お兄さん/ 様	elder brother
boku, ore [male] ぼく、俺	watakushi 私(わたくし)	I
chichi 父	otō-san/sama^{1,2} お父さん/様	father

Neutral (Non-Respectful)	Polite/Respectful	Meaning
haha 母	okā-san/sama^{1,2} お母さん/様	mother
imōto 妹	imōto-san¹, imōto-sama¹ 妹さん、妹様	younger sister
kodomo, ko 子供、子	kodomo-san, o-ko-san/sama¹ 子供さん、 お子さん/様	child
kyaku 客	o-kyaku-san/sama¹ お客さん/様	visitor, guest
musuko 息子	musuko-san, go-shisoku 息子さん、ご子息	son
musume 娘	musume-san, ojōsan/sama¹ 娘さん、 お嬢さん/様	daughter
oba 伯母[叔母]	oba-san/sama^{1,2} 伯母[叔母]さん/様	aunt
oji 伯父[叔父]	oji-san/sama^{1,2} 伯父[叔父]さん/様	uncle
otto, shujin 夫、主人	go-shujin, go-shujin-sama, danna-sama ご主人、ご主人様、 旦那様	husband, master

Neutral (Non-Respectful)	Polite/Respectful	Meaning
otōto 弟	otōto-san/sama ¹ 弟さん/様	younger brother
ryōshin 両親	go-ryōshin, go-ryōshin-sama ご両親、ご両親様	parents
sobo 祖母	o-bāsan/sama ^{1,2} おばあさん/様	grandmother/ old lady
sofu 祖父	o-jiisan/sama ^{1,2} おじいさん/様	grandfather/ old man
tsuma, kanai, nyōbō 妻、家内、女房	okusan/sama ¹ 奥さん/様	wife
watashi 私(わたし)	watakushi 私(わたくし)	I
dare 誰	donata, donata-sama, dochira-sama どなた、どなた様、 どちら様	who?
dō (desu ka etc.) どう(ですか)	ikaga (desu ka etc.) いかが(ですか)	how (is it? etc.)
doko どこ	dochira どちら	where?
dore どれ	dochira どちら	which?
asoko/are あそこ/あれ	achira あちら	(over) there/ that (one)
koko/kore ここ/これ	kochira こちら	here/this (one)

Neutral (Non-Respectful)	Polite/Respectful	Meaning
soko/sore そこ/それ	sochira そちら	there/that (one)
-domo, -tachi ども、たち	-gata 方	(plural suffix)
hito, (mono) 人、(者)	kata, -sama (e.g. achira-sama, mina-sama) 方、-様 (あちら様、皆様)	person
plain word	o-, go-, on-, omi- お-, ご-, 御-、 御御-	(polite/ honorific suffix)
(family name only), -kun ³ 君	-san, -sama- さん、-様	(hon. suffix) Mr. etc.

Notes

1. さん **-san** has 様 **-sama** as a more formal and respectful alternative in these words (i.e., except for 父さん **tō-san**, words which also have an initial お **o**).
2. さん **-san** has ちゃん **-chan**, and 様 **sama** has ちゃま **-chama**, as rather childish "family" alternatives in these words (i.e. words used in close family relationships).
3. Not used by or with reference to women. They use さん **-san** or 様 **-sama** (unless referring to their own husbands, when names alone are commonly used), and are themselves referred to as さん **-san** or 様 **-sama** when called by their family names.

APPENDIX 3

Table of Verbs

The verbs are listed in ascending order of respect.

Standard Form	Neutral (No feeling of respect or humility)	Honorific Respect to subject	Deprecatory Respect to person or thing, not the subject
	Dictionary forms	お + base + になる / なさる <i>ni naru/nasaru</i> ; お + (ら)れる <i>(ra)reru</i> passive forms	お + base + する / いたす <i>suru/itasu</i>
だ <i>da</i> "be"	でいる <i>de iru</i> である <i>de aru</i>	でいらっしゃる <i>de irassharu</i> , でおいでになる <i>de oide ni naru</i> (with animate subjects only)	(だ) (<i>da</i>)
ある <i>aru</i> "exist"		(だ) (<i>da</i>), におありになる <i>de o-ari ni naru</i>	(だ) (<i>da</i>)
いる <i>iru</i> "be (present)"		おありになる <i>o-ari ni naru</i>	(ある) (<i>aru</i>) (いる) (<i>iru</i>)
行く <i>iku</i> "go"		いらっしゃる <i>irassharu</i> , おいでになる <i>oide ni naru</i>	
来る <i>kuru</i> "come"		いらっしゃる <i>irassharu</i> , おいでになる <i>oide ni naru</i> (みえる <i>mieru</i> , おみえになる <i>o-mie ni naru</i> "put in appearance" only)	参る <i>mairu</i>
出る <i>deru</i> "emerge"		お出になる <i>o-de ni naru</i> (みえる <i>mieru</i> , おみえになる <i>o-mie ni naru</i> "put in appearance" only)	(出る) (<i>deru</i>)
言う <i>iu/yū</i> "say"		おっしゃる <i>ossharu</i>	
する <i>suru</i> "do"		なさる <i>nasaru</i>	申す <i>mōsu</i> , 申し上げる <i>mōshiageru</i> (する) (<i>suru</i>), いたす <i>itasu</i>
聞く <i>kiku</i> "ask, hear"		お聞き/おたずねになる <i>o-kiki/o-tazune ni naru</i>	伺う <i>ukagau</i> , お聞き/たずねする/いたす <i>o-kiki/o-tazune suru/itasu</i> , お伺いする/いたす <i>o-ukagai suru/itasu</i> ; 承る <i>uketamawaru</i> = 聞く <i>kiku</i> "hear" only
たずねる <i>tazuneru</i> "inquire, visit"		お呼びになる <i>o-yobi ni naru</i> , 召す <i>mesu</i> , <i>o-meshi ni naru</i>	お呼びする/いたす <i>o-yobi suru/itasu</i>
呼ぶ <i>yobu</i> "call"		お借りになる <i>o-kari ni naru</i>	お借りする/いたす <i>o-kari suru/itasu</i> , 拝借する/いたす <i>haishaku suru/itasu</i>
借りる <i>kariru</i> "borrow"		ご連絡/なさる <i>go-renraku etc./nasaru</i>	ご連絡する/いたす <i>go-renraku suru/itasu</i>
連絡する <i>renraku etc. suru</i>		ご勉強/なさる <i>go-benkyō etc./nasaru</i>	勉強する (<i>benkyō suru</i>)
勉強する <i>benkyō etc. suru</i>		ご存知になる <i>go-zonji ni naru</i>	
知る <i>shiru</i> "know"		お思いになる <i>o-omoi ni naru</i> , 思し召す <i>oboshimesu</i>	存じ上げる <i>zonjiageru</i>
思う <i>omou</i> "think, feel"		下さる <i>kudasaru</i>	いただく <i>itadaku</i> , ちょうだいする/いたす <i>chōdai suru/itasu</i>
くれる <i>kureru</i> "condescend"		おもらいになる <i>o-morai ni naru</i>	
もらう <i>morau</i> "receive"		上がる <i>agaru</i> , お上がりになる <i>o-agari ni naru</i> , 召し上がる <i>meshiageru</i>	いただく <i>itadaku</i> , ちょうだいする/いたす <i>chōdai suru/itasu</i>
食べる <i>taberu</i> "eat"		お飲みになる <i>o-nomi ni naru</i> , 上がる <i>agaru</i> , お上がりになる <i>o-agari ni naru</i> , 召し上がる <i>meshiageru</i>	
飲む <i>nomu</i> "drink"		ご覧になる <i>goran ni naru</i>	拝見する/いたす <i>haiken suru/itasu</i>
見る <i>miru</i> "see"		お見せになる <i>o-mise ni naru</i>	お目にかける <i>o-me ni kakeru</i> , ご覧にかける/いれる <i>goran ni kakeru/ireru</i>
見せる <i>miseru</i> "show"		お会いになる <i>o-ai ni naru</i>	お会いする/いたす <i>o-ai suru/itasu</i> , お目にかかる <i>o-me ni kakaru</i> "meet person" only
会う <i>au</i> "meet"		お亡くなりになる <i>o-nakunari ni naru</i>	(死ぬ) (<i>shinu</i>)
死ぬ <i>shinu</i> "die"		お亡くなりになる <i>o-nakunari ni naru</i>	(亡くなる) (<i>nakunaru</i>)
亡くなる <i>nakunaru</i> "die, disappear"		おやりになる <i>o-yari ni naru</i>	"give" only: あげる <i>ageru</i> , 差しあげる <i>sashiageru</i>
やる <i>yaru</i> "send, give"		おあげになる <i>o-age ni naru</i>	
あげる <i>ageru</i> "raise, give"		召す <i>mesu</i> , お召しになる <i>o-meshi ni naru</i>	(着る) (<i>kiru</i>)
着る <i>kiru</i> "wear"		FOR ALL OF THE ABOVE: and certain passive forms	
-ます <i>-masu</i> forms of above verbs		-ます <i>-masu</i> forms of above verbs (or the above forms themselves when used in addressing their subject in "respectful familiar" speech)	-ます <i>-masu</i> forms of above verbs

Deprecatory Humble	Affirmative Plain Level	Honorific Imperative	Honorific Imperative
でおります <i>de orimasu</i> (with animate subjects only)	でございます <i>*de gozaimasu</i> [である <i>de aru</i> , だ <i>da</i> , な <i>na</i> , の <i>no</i>]	でいらっしゃい <i>de irasshai</i> (with animate subjects only)	
ございます <i>*gozaimasu</i> [ある <i>aru</i> , の <i>no</i>]			
おります <i>*orimasu</i>		いらっしゃい <i>irasshai</i>	
参ります <i>*mairimasu</i>			
		おっしゃい <i>osshai</i>	
		なさい <i>nasai</i>	
お聞き 申します/申し上げます <i>o-kiki etc. mōshimasu/mōshiagemasu</i>			
お借り/拝借 申します/申し上げます <i>o-kari/haishaku mōshimasu/mōshiagemasu</i>			
ご連絡 申します/申し上げます <i>go-renraku mōshimasu/mōshiagemasu</i>			
勉強いたします <i>benkyō itashimasu</i>			
存じます <i>zonjimasu</i>			
		下さい <i>kudasai</i>	
		召し上がれ <i>meshiagare</i>	
		FOR ALL OF THE ABOVE:	
		and なさい <i>nasai</i> for the になる <i>ni naru</i> or なさる <i>nasaru</i> of all honorifics using them	
		ませ/まし <i>-mase/-mashi</i> forms of all verbs used at the Lower Level e.g. おっしゃいませ/まし <i>osshaimase/-mashi</i> , おいでなさいませ/まし <i>oide nasaimase/-mashi</i> .	
		いらっしゃる な <i>irassharu na</i>	いらっ しゃいます な <i>irasshaimasu na</i>
		おいで なさる な <i>oide nasaru na</i>	おいで なさいます な <i>oide nasaimasu na</i>
		召し上がる な <i>meshiageru na</i>	召し上がります な <i>meshiagarimasu na</i>
		ご覧 なさる な <i>goran nasaru na</i>	ご覧 なさいます な <i>goran nasaimasu na</i>
		(These forms are usually replaced, however, by circumlocutions such as ないで 下さい <i>-nai de kudasai</i> , て は いけません <i>-te wa ikemasen</i> .)	

Note: The forms in this table are listed in ascending order of respect. The forms in the Affirmative Imperatives column are used in addressing the subject in "respectful familiar" speech.

APPENDIX 4

Table of Adjectival Forms

PLAIN	POLITE	DEFERENTIAL	HONORIFIC
(No respect to personal addressed)	(to person addressed)	(Respect to person addressed or, in loose usage, to subject)	(Respect to subject)
元気だ genki da	(お)元気です (o-)genki desu	(お)元気でございます (o-)genki de gozaimasu	(お)元気でいらっしゃる (o-)genki de irassharu
元気な [genki na]	(お)元気な [(o-)genki na]	(お)元気な [(o-)genki na]	(お)元気な [(o-)genki na]
若い wakai	(お)若いです (o-)wakai desu	(お)若う ございます (o-)wakō gozaimasu	(お)若く(て) いらっしゃる (o-)wakaku(te) irassharu
若い [wakai]	(お)若い [(o-)wakai]	(お)若い [(o-)wakai]	(お)若い [(o-)wakai]
大きい ōkii	大きいです ōkii desu	大きゅう ございます ōkyū gozaimasu	大きく(て) いらっしゃる ōkikute(te) irassharu
大きい [ōkii]	大きい [ōkii]	大きい [ōkii]	大きい [ōkii]
寒い samui	(お)寒いです (o-)samui desu	(お)寒う ございます (o-)samū gozaimasu	(お)寒く(て) いらっしゃる (o-)samuku(te) irassharu
寒い [samui]	(お)寒い [(o-)samui]	(お)寒い [(o-)samui]	(お)寒い [(o-)samui]
重い omoi	重いです omoi desu	重う ございます omō gozaimasu	重く(て) いらっしゃる omoku(te) irassharu
重い [omoi]	重い [omoi]	重い [omoi]	重い [omoi]

Notes

1. Square brackets enclose the forms normally used before nouns.
2. An honorific prefix (usually お o-) can be used at any but the plain level of politeness with most adjectives, provided the respected person is in some way concerned and there is not already an initial o. (The prefix ご go- is used with some “な na adjectives”, but even with these the use of お o- is more common than ご go- when the word is felt to be an adjective rather than a noun.)

Achira 28-29, App. 2
 adjectives 139, App. 4
agaru 55, 58, App. 3
ageru = give 78, 113, App. 3
anata 30, App. 2
ane App. 2
ani App. 2
are 28, App. 2
aru 60, 80-81, 122-123, App. 3
asobasu 135, App. 3
asoko 28, App. 2
au 61, 83-86, App. 3

Bāsan 34, 46-47, App. 2
benkyō 53, 67, 80-82, 117,
 App. 3
boku App. 2
botchan App. 2

Causative verbs 98-99, 102-
 109, 110, 113
cha 31
-chan, -chama 39-41, App. 2
chichi 35, 48, App. 2
chōdai 78-79, 83-86, 108-109,
 App. 3

Da 55, 60, 67, 68-69, 80-81,
 115, 123, 125, App. 3
dare 30-31, 44, 49, App. 2
de aru 60, 122-123, App. 3
 deferential forms: of verbs
 115-128, App. 3; of adj.-cs.
 141-143, 143-144, App. 4

de gozaimasu 116, 117-120,
 122-123, App. 3
de irassharu 55, 68-69, 115-
 116, 125, 131, 143-144,
 App. 3
de iru App. 3
de o-ari ni naru 60, 125-126,
 App. 3
de oide ni naru 55, 125, 143,
 App. 3
de orimasu 115-116, App. 3
 depreciatory forms of verbs
 52, 115, 126-128, App. 3;
 standard forms 75-94;
 permissive constrns. 97-113
deru App. 3
desu 60, 116, *see also da*
dochira 28-29, 38, 49, 92,
 App. 2
doko 28, App. 2
-domo 150 fn., App. 2
donata 30-31, 38, 49, App. 2
dō 27, 141, App. 2
dore 28, 29, App. 2

-gata 150 fn., App. 2
go- 31-33, 139-140, Apps. 2
 & 4
goran 55, 78-79, App. 3
gozaimasu 117-120, 122-126,
 App. 3
go-zonji ni naru 55, 56,
 App. 3

Haha 35, App. 2
hai 82
haiken 78-79, 82, 108, App.
 3
haishaku 83-86, App. 3
henji 32, 134
hito 29-30, 45, 49, App. 2
 honorific forms: of verbs
 51-52, 126-128, App. 3;
 standard forms 52-65, 71;
 misc. forms 67-73; imper.
 forms 131-137; of adjcs.
 143-144, App. 4
 honorific prefixes 31-33,
 34-43, 52-53, 139-140,
 Apps. 2 & 4
 honorific suffixes 33-43,
 App. 2

Ii 141, 142, App. 2
ikaga 27, 29, 53, 141, App. 2
iku 55, 78-79, App. 3
imōto 33, 35, 36, 38, 40, 45,
 App. 2
 imperative forms 131-137,
 App. 3
irassharu 55, 58, 131, 143-
 144, App. 3
iru 55, 80-81, 117, App. 3
itadaku 78-79, 83-86, 94,
 97-113, App. 3
itasu 76, 78-79, 116, 117,
 App. 3

Jama 31, 107
jiisan 34, App. 2

Kāsan 35, 39-40, 44, App. 2
kanai 48, 63, App. 2
kariru 83-86, App. 3
kata 29-30, 47, 49, App. 2
kiku = "wear" 55, 72, App. 3
ko 35, 37, App. 2
kochira 28-29, App. 2
kodomo App. 2
koko 28, App. 2
kore 28, App. 2
kudasaru 55, 131, 133-134,
 App. 3
-kun App. 2
kureru 55, App. 3
kuru 55, 78-79, 119, App. 3
kyaku 31, 35, 37, App. 2

Letters 16

-mase/-mashi 134-136, App. 3
-masu 69-71, 90-92, 93-94,
 115, 121-122, 126-127,
 App. 3
mairu 78-79, 117-118, 121-
 122, 126-128, App. 3
meshiageru 55, 58, 131, 133,
 App. 3
mesu 55, 58, 72-73, App. 3
mi- 140
mieru 55, App. 3
mina App. 2

miru 55, 61, 78-79, App. 3
miseru 78-79, App. 3
mono = "person" App. 2
mōshigeru 78-79, 116-117, App. 3
mōsu 78-79, 116-117, 126-128, App. 3
morau 61-63, 78-79, 97-113, App. 3
musuko 33, 36, 37, App. 2
musume 33, 35, 36, 37, App. 2

Na, attrib. part 122-123, 124
na, neg. imper. part. 136, App. 3
nakunaru 55, 80-81, App. 3
nasaru 52-53, 55, 131, 135, App. 3
nēsan 34, 36, 40, App. 2
neutral language 17-25
niisan 34, 36, 37, 44, App. 2
no 122-123, 124
nomu 58, App. 3
nyōbō App. 2

O- 31-33, 52-53, 139-140, App. 2 & 4
o-ari ni naru 60, 125-126, App. 3
oba 35, 39-40, App. 2
o-bāsan, o-kāsan etc.: *see* **bāsan, kāsan** etc.
oboshimesu 58, App. 3

ofukuro App. 2
oide ni naru 55, 58, App. 3
oji 35, 39, App. 2
ojōsan 35, 36, 37, App. 2
okusan 34, 35, 37, 47, App. 2
o-me ni kakaru 83-86, 91-92, 94, App. 3
o-me ni kakeru 78-79, App. 3
omi- 140, Apps. 2 & 4
omou 58, 78-79, 116, App. 3
on- 31, App. 2
ōi 143
ōkii 140, App. 4
ore App. 2
orimasu 117-119, 122, 126-128, App. 3
ossharu 55-131, App. 3
otōto 35, 37, 40, 44, App. 2
otto App. 2
oya App. 2
oyaji App. 2
oya-tachi App. 2

Passive form: as honorific 63-65, 126-128; "indirect" _____ 64-65, App. 3
permissive constrns. 97-113
plural suffixes 150 fn., App. 2
polite words 27-29, 67, App. 2
prefixes: *see* honorific prefixes

"Receive" 61-63
renraku 53, 67, 76-77, 81-82, App. 3

respect: to subject, *see*
honorific forms; to 2nd & 3rd persons 75-76, 86-94, 109-110, 115, 121-122, 126-128, App. 1; *see also* respectful language
respectful language 15-25
respectful words 29-49, 67, App. 2
ryōshin 38, App. 2

-san 33-43, 44, App. 2
-sama 36-43, 44, App. 2
sashiageru 78-79, App. 3
shinu 55, 80-81, App. 3
shiru 55, 78-79, 116, App. 3
shitsurei 82, 102
shujin App. 2
sobo App. 2
sochira 28-29, App. 2
social relationships 17-25, App. 1
sofu App. 2
soko 28, App. 2
sōdan 53-54, 68, 77, 81-82
sore 28, App. 2
standard (social) situations 17-25, App. 1
suffixes: *see* honorific _____, plural _____
suru 55, 71-72, 78-79, 116, 117, App. 3

Taberu 55, 78-79, App. 3

-tachi 150 fn., App. 2
tazuneru 55, App. 3
-te form 98-113, 133-134
tōsan 35, 37, 40, 45, 47, App. 2

Ukagau 83-86, App. 3
uketamawaru 83-86, App. 3
uketoru 61-63

Verbal nouns 67, 98, 134
verbs App. 3; *see also* honorific _____, depreciatory _____, deferential _____, imperative forms, & individual verbs

Watakushi/watashi 27, 29, App. 2
women's language 16, 32, 70
writing: *see* letters

Yaru = "give, send" 78-79, 112-113, App. 3
yobu 58, 72, App. 3
yoroshii 141, App. 2
yukkuri 31-32
yū 55, 78-79, App. 3

Zonjiageru 78-79, 119, App. 3
zonjimasu 116-119, App. 3

Published by Tuttle Publishing, an imprint of Periplus Editions (HK) Ltd., with editorial offices at 364 Innovation Drive, North Clarendon, Vermont 05759 U.S.A. and at 61 Tai Seng Avenue #02-12, Singapore 534167

Copyright © 1966 P. G. O'Neill and the School of Oriental and African Studies
First edition originally published 1966 by Hodder and Stoughton Ltd., England
First Tuttle Publishing edition, 1983

Updated Tuttle Publishing edition, 2008

Published by arrangement with Hodder and Stoughton Ltd.

All rights reserved. No part of this publication may be reproduced or utilized in any form or by any means, electronic or mechanical, including photocopying, recording, or by any information storage and retrieval system, without prior written permission from the publisher.

Library of Congress Cataloging-in-Publication Data

O'Neill, P. G. (Patrick Geoffrey), 1924-
Japanese respect language : when, why, and how to use it successfully / P. G. O'Neill.
p. cm.
Includes index.
ISBN 978-4-8053-0976-6 (pbk.)
1. Japanese language--Honorific. I. Title.
PL629.H65O54 2008
495.6'5--dc22

2008027109

ISBN 978-4-8053-0976-6

Distributed by

*North America, Latin
America & Europe*
Tuttle Publishing
364 Innovation Drive
North Clarendon,
VT 05759-9436 U.S.A.
Tel: 1 (802) 773-8930
Fax: 1 (802) 773-6993
info@tuttlepublishing.com
www.tuttlepublishing.com

Japan
Tuttle Publishing
Yaekari Building, 3rd Floor
5-4-12 Osaki
Shinagawa-ku
Tokyo 141 0032
Tel: (81) 03 5437-0171
Fax: (81) 03 5437-0755
tuttle-sales@gol.com

Asia Pacific
Berkeley Books Pte. Ltd.
61 Tai Seng Avenue #02-12
Singapore 534167
Tel: (65) 6280-1330
Fax: (65) 6280-6290
inquiries@periplus.com.sg
www.periplus.com

First edition

12 11 10 09 08 10 9 8 7 6 5 4 3 2 1

Printed in Singapore

TUTTLE PUBLISHING® is a registered trademark of Tuttle Publishing,
a division of Periplus Editions (HK) Ltd.

Who Should Use This Book

Japanese Respect Language is intended for learners who are already familiar with modern colloquial Japanese and its basic grammar, including the use of passive and causative verbs; but no previous knowledge of respect language is required.

It's appropriate for learners at an intermediate level of study in a college or university course. More specifically, the teaching method used here was primarily designed for and tested on students who had completed a total of 250 to 300 class hours of Japanese language study, but who had encountered no respect forms beyond the ordinary **masu**-level endings.

Contents

What Does It Teach?

Japanese Respect Language is intended to enable learners with the appropriate previous knowledge to understand the significance of and use respect forms, both in isolated sentences and larger-context text, by identifying

- (i) the type of respect form used (e.g. honorific verb).
- (ii) the person to whom respect is being shown.
- (iii) the equivalent form in the colloquial language at the ordinary **masu** level of politeness.

Japanese Respect Language deals with the combinations of the standard social relationships among the 1st, 2nd and 3rd persons, and their effect on the politeness level of the language used. It covers the main lexical equivalents for uninflected words at different levels of politeness; the various verbal constructions used in respect language (honorifics, depreciatories and deferentials, permissive **-te morau/itadaku** constructions, and imperative forms); and the use of adjectives in respect language.

Acknowledgments	9
Introduction	10
CHAPTER 1. The Basics of Respect Language	15
CHAPTER 2. Polite and Respectful Words	27
CHAPTER 3. Honorific Verbs: (a) Standard Forms	51
CHAPTER 4. Honorific Verbs: (b) Miscellaneous Forms	67
CHAPTER 5. Depreciatory Verbs: (a) Standard Forms	75
CHAPTER 6. Depreciatory Verbs: (b) Permissive Constructions ...	97
CHAPTER 7. Deferential Verbs	115
CHAPTER 8. Imperative Forms	131
CHAPTER 9. Adjectives	139
Practice Readings with Exercises	145
Review Exam	169
Appendix 1: Standard Situation Diagrams	174
Appendix 2: Polite and Respectful Words	176
Appendix 3: Table of Verbs	180
Appendix 4: Table of Adjectival Forms	182
Index	185

Acknowledgments

I have received help of various kinds at different stages of this work, and I should like to record my appreciation here. First, I must thank the School of Oriental and African Studies, University of London, for providing the grant which made the publication of this course possible. Then, Professor E. H. Jorden of the Foreign Service Institute, Washington, D.C., Mrs. Marleigh Ryan and Dr. Ivan Morris of Columbia University, and Mr. S. Parker of the Holborn College of Law, Languages and Commerce, were all good enough to test intermediate drafts of the course on their students; Professor E. G. Wenck of the University of Hamburg made several helpful suggestions on points of detail; and my colleagues at the School of Oriental and African Studies have throughout been a source of encouragement and enlightenment. My thanks are owed particularly to Mr. Kikuo Nomoto of the National Language Research Institute, Tokyo, and temporarily Visiting Lecturer in Japanese at the School, and to Mr. F. J. Daniels, Professor of Japanese at the University of London. Professor Daniels is one of the few people to have worked on the problems of respect language, and his unfailing readiness to discuss and advise on them was invaluable. I know, however, that he would not necessarily agree with all the aspects of the analysis involved in this course, and its deficiencies remain my own.

from the original edition, London, 1965

P. G. O'Neill

Introduction

Respect language—the special style of polite spoken or written Japanese—is involved in almost every exchange of Japanese between one person and another, including the simplest phrases of greeting. An understanding of its forms is therefore essential to any serious student of the Japanese language.

This book is intended for learners of Japanese who are already familiar with modern colloquial Japanese and its basic grammar, but it requires no previous knowledge of respect language.

Step by step, the basic and correct forms that you should master for your own use are taught in *Japanese Respect Language*. First, we look at the various typical situations to see *when* respect should and should not be shown in Japanese, and then we go on to see *how* respect is expressed in special forms of speech. In this way, you'll learn how to identify the type of respect form used, the person to whom respect is being shown, and the equivalent form in colloquial language.

Respect language in Japanese today is not as clear as it once was. Some distinctions between forms have become blurred; much spoken Japanese, in particular, mixes basic and variant forms, and respectful and plain forms, without regard to consistency of style. There are, indeed, so many differences in usage between men and women, with further distinctions according to social and regional background, that many of the finer points of usage admit of no clear agreement, even among educated Japanese.

All this makes it very difficult for the learner to pick his or her way unguided through the maze of respect forms. It also

makes the structure of this book particularly important: a simple, measured, point by point approach. Brief practice sections, all requiring constructed responses (with the exception of a few multiple choice questions), help you to review your understanding as you read.

Contents include sections on polite and respectful words; honorific verbs; depreciatory verbs; deferential verbs; imperative forms; and adjectives.

At the end of the book are four passages of practice material, and a Review Exam to measure your acquired ability. Four invaluable appendices offer quick reference.

For the non-native learner to gain a ready command of Japanese respect language's niceties for use in his or her own conversation requires practice in a real-life setting, and no written course can replace that. But the aim here is to provide an understanding of how respect language works, and develop the ability to identify its different forms accurately when they are met in conversation or reading. Having gained this understanding, through the tried and tested approach of this book, you will only need a minimum of "live" practice to be able to use respect language correctly in your own speech or writing.

This book has therefore had to be made to some extent both prescriptive and descriptive: it teaches primarily the main basic and "correcter" forms which the learner should master for his or her own use, but it also describes enough variants from these to enable him or her to recognize and identify these too without difficulty.

In Chapter 1's explanations of how respect language works, the rules given for its use in standard social situations are of necessity generalizations. It is possible to suggest particular circumstances in which these rules would not always apply, and these cases could have been covered by describing the role of the third person or the characteristics of women's speech, for example, in much greater detail. The explanation has not

been taken that far, however, because the resulting complexity would have obscured the main framework of the system used in this book. The basic situations presented in *Japanese Respect Language* provide guidance to a wide range of general usage, and they are intended to act as points of reference against which minor variant usages can later be set and evaluated.

A Few Notes

Parentheses in Japanese examples indicate that the word or words enclosed may be omitted; thus A(B) = A or AB.

A raised plus sign ⁺ after a word indicates that additional derived forms are to be understood as included with the basic form cited; thus, **da⁺** can signify **da**, **desu**, **data**, **deshita**, **darō**, etc., as appropriate.

CHAPTER 1

The Basics of Respect Language

Respect language means the special style of speech or writing used in Japanese to show respect to persons and, occasionally, to especially revered things (e.g. a shrine, the Imperial palace).

Japanese uses a special style of language to express respect, and this special style we call respect language.

Neutral language does *not* take any special measures to express respect. We call the style which uses few or no honorific or humble words neutral language.

A speaker or writer (the 1st person) can direct his respect wherever he wishes; to the person he is addressing (the 2nd person); to another person or thing he is talking about (the 3rd person); or to both the 2nd and 3rd persons.

Respect can be shown both to the person one is talking to and to the person one is talking about.

Very often these will be one and the same person. One frequently talks *to* and *about* the same person.

Whenever a person speaks or writes, he decides for himself to whom and to what extent he will show respect.

The use of respect language varies with the individual and his particular circumstances at the time.

Because of this, exceptions are always possible; but our own ideas of politeness are a good basis on which to judge when respect is appropriate.

Understanding the Japanese attitude to politeness and respect thus causes us no great difficulty.

In English, however, such feelings are expressed in words much less than in Japanese.

Politeness and respect are much *more* obvious in Japanese than in English.

Hence, we'll first look briefly at various typical situations to see *when* respect would and would not be shown in Japanese, and then go on to see in detail *how* respect is expressed by special forms of speech.

Everyone uses some degree of respect language at times, particularly in letters.

Japanese in general are even more respectful to each other in letters than in speech.

Women, however, use respect language more consistently and extensively than other people.

Thus, the special forms of respect language are met most often in letters, and in the language used by women.

Women make more use of respect language than men because they tend to be more *formal* in their letters and speech.

Respect language indicates some degree of formality between the people concerned.

For example, when two people meet for the first time, the formality of the occasion usually causes a reciprocal display of respect language.

This soon becomes tiresome, however, and men in particular will gradually adopt a more informal tone.

They become more informal by reducing their use of respect language until it has few or no honorific or humble words; that is, until it is neutral language.

Neutral language is thus a mark of comparative informality.

In an informal situation, then, a speaker will normally use neutral language.

Neutral language is much used when a person is talking to someone of his own circle (family, business office, etc.), because this is usually an informal situation.

Since, grammatically, the speaker is the 1st person and the person addressed is the 2nd person, we can represent one person talking to another *of the same circle* by using ① for the 1st person and ② for the 2nd person.

If ① and ② are more or less equals, we can represent their talking together by this diagram:



Since this is an informal situation, ① would use neutral language.

Let us show this too by adding N for Neutral language:



This shows that when a person talks to an equal belonging to his own circle, he uses neutral language.

He would do the same if ② were *junior* to him in age or status.

The following diagram shows this situation and the language used:



If ② is *equal or junior* to ①, then, neutral language will be used.

In fact, it is only when ② is *senior* to ① that respectful language is normally used. In talking to someone *senior*, one is respectful. This diagram shows it:



① uses R (respectful language) to ②, then, only when ② is senior to him.

The following diagram brings together the three basic relationships between two people of the same circle, and the type of language used in each case.

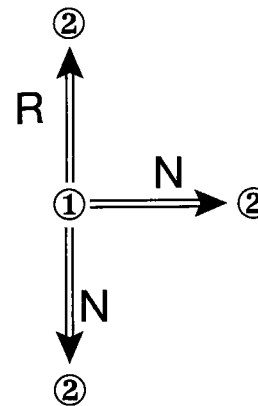

In two situations out of three, then, a person talking to someone of his own circle will use neutral language.

He would, of course, do the same if he was talking *about* the 2nd person as well as *to* him.

Whether a person talks merely *to* someone or *to and about* him, he will show him the same respect.

If we now use an extra single line to indicate the person talked *about*, the following diagram

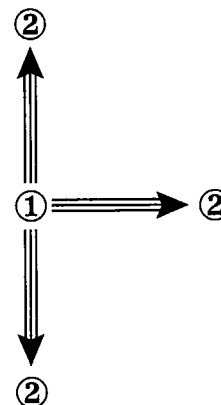

shows one person talking to and about another person belonging to his own circle.

Whether ① talks to or to and about ②, the type of language used is the same...

as this diagram shows by giving letters for the language used in each of the three situations.

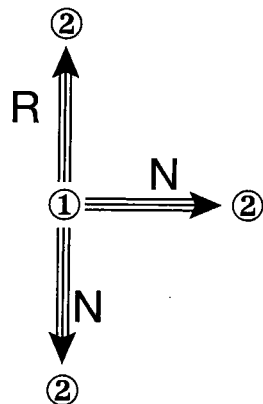

Hence, a girl talking to (or to and about) her father will generally use respectful language to him;

and an office clerk talking to (or to and about) his manager will use respectful language;

but the clerk talking to (or to and about) another clerk will use neutral language.

A 3rd person (a person talked *about* but not talked *to*) is also treated in the same way if he is present and if he, the speaker, and the person addressed all belong to the same circle.

The following diagram illustrates this, showing the language used about such a 3rd person.

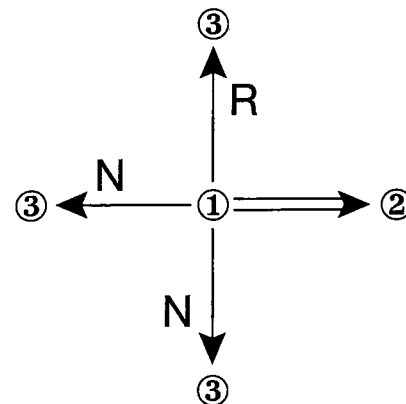

If he is *not* present when he is mentioned, a speaker will be less likely to show respect to him.

If he is not present when he is mentioned, then, ③ will often be talked about in neutral language regardless of his status.

As you can see from the diagram above, this only makes a difference to the language used about ③ when he is senior to the speaker.

We can amend the diagram to cover this situation, by adding a *dotted* line to indicate a 3rd person who is *absent*, and of the same circle as ① and ②:

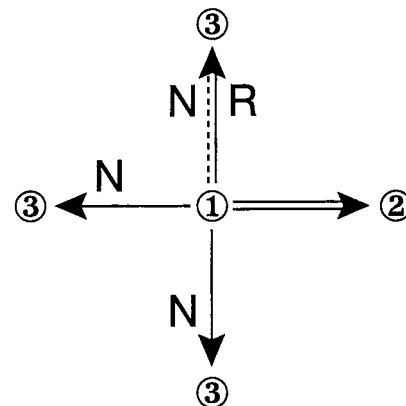

Hence, one secretary talking to another about the manager in his presence would use respectful language about him.

A teacher talking to a colleague about a third teacher who is present would use neutral language about him. (Since the teachers are all of the same standing, the presence of the one being referred to is irrelevant.)

One actress asking another where their agent is would use neutral language about him.

If, in talking to an outsider (i.e. to a 2nd person not of his own circle: ■), a speaker mentions a 3rd person belonging to his own circle, he will very rarely show respect to that person:

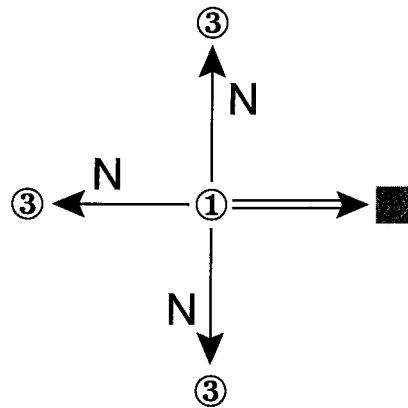

It is inappropriate to show respect to someone associated with oneself when talking to an outsider.

A boy talking to his teacher would refer to his father in neutral language.

On the other hand, a Japanese will normally use respectful language to an outsider—especially if he does not know him very well—unless the other person is clearly junior to him in age or status.

He will therefore use respectful language towards an outsider in two of our three typical senior-equal-junior relationships.

In the other junior relationship he would normally use neutral language towards ■. The situation diagram would be (a), or its modified form (b) if he talked *about* as well as *to* the outsider.

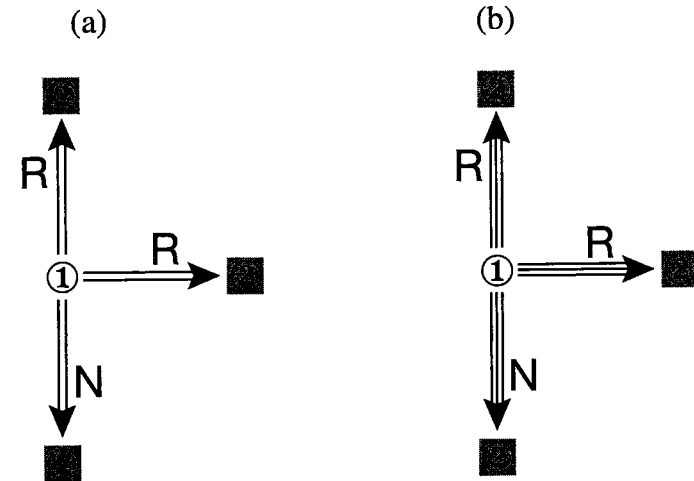

A traveller would talk to a hotel porter in neutral language.

A bank manager would address a client in respectful language.

Respectful language would be used to the same extent about someone associated with ■ and not of the speaker's own circle (i.e. a 3rd person who can be represented by ■).

The following diagram represents this situation; notice the R indicating respectful language used with reference to the 3rd person.

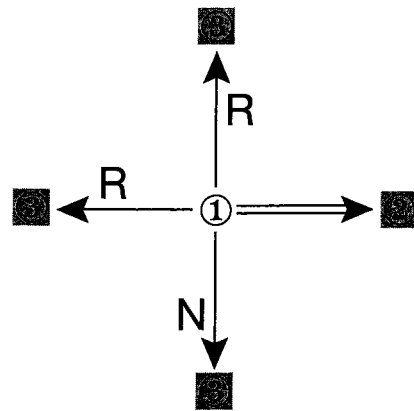

A person asking a neighbor about her husband would use respectful language about him.

A woman talking to a delivery person about his younger brother would use neutral language about him.

The only other situation we need to consider is that of someone talking about a 3rd person unconnected with either himself or the person addressed. We can represent such a person thus: ③.

If this 3rd person is junior to the speaker, there will be no need to refer to him in anything more than neutral language. If he is senior to the speaker, he will be referred to with respect. And if he is felt to be more or less at the speaker's own level, he will probably be talked of in respectful language if he is within hearing, and in neutral language if he is not.

This diagram reflects the appropriate language.

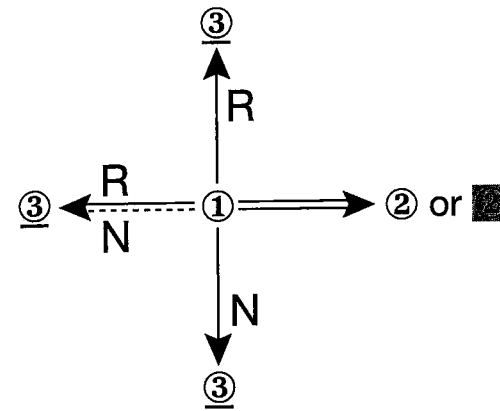

A critic being interviewed publicly about an actor in his presence would normally refer to him in respectful language.

An officer talking to another officer about the emperor in his absence would use respectful language in referring to him.

A father talking to a teacher about the absent parent of another child would use neutral language in referring to him.

Thus, we can say that, in general:

- (i) a speaker will show respect to a member of his own circle only when that person is clearly senior to him and when no outsider is present.
- (ii) a speaker will show respect to an outsider (and anyone connected with such an outsider and not with himself) unless that person is clearly junior to him.
- (iii) in doubtful cases, a speaker is more likely to show respect to a person if he is present than if he is not.

CHAPTER 2

Polite and Respectful Words

Having seen something of the situations in which respect normally would and would not be shown, let's now consider how respect is expressed in Japanese when it is felt to be required.

The simplest way is by the use of special non-verb forms (including certain nouns, pronouns and adverbs) in place of the ordinary neutral words with the same meanings. Some of these you will have already met; others may be new to you.

私(わたくし) **Watakushi**, for example, you probably know as a formal equivalent for the ordinary 1st person pronoun 私(わたし) **watashi** "I".

Respect is never directed to oneself and the formality of 私(わたくし) **watakushi** adds an air of politeness directed instead at the person to whom it is used; that is, to the 2nd person.

Similarly, the use of いかが **ikaga**, a polite equivalent for どう **dō** "how?" in such phrases as いかがですか **ikaga/dō desu ka**, also has the effect of showing politeness to the 2nd person.

Thus, if a neighbor is ill, one would probably ask his young child about him by using the neutral interrogative word どう **dō**, whereas one would be more likely to say to his wife "How is he?":

いかがですか。 **Ikaga desu ka.**

The “directional” words こちら **kochira**, そちら **sochira**, あちら **achira** and どちら **dochira** can also be used to produce the same general atmosphere of politeness.

In normal usage these words mean respectively “this direction”, “that direction”, “that direction (over there)” and “which direction?”.

But in polite usage, こちら **kochira** can replace これ **kore** “this (one)” or ここ **koko** “here” and similarly, そちら **sochira** can replace それ **sore** “that (one)” or そこ **soko** “there”;

あちら **achira** can replace あれ **are** “that (one over there)” or あそこ **asoko** “that place (over there)”;

and どちら **dochira** can replace どれ **dore** “which (one)?” or どこ **doko** “where?”.

Hence, in a telephone conversation a speaker will commonly refer to things connected with himself by using こちら **kochira** instead of これ **kore** or ここ **koko**,

and to things connected with the other person by using そちら **sochira** instead of それ **sore** or そこ **soko**.

Similarly, when asking “Where is your home?; Where do you come from?”, Japanese will regularly say not

お国はどこですか。 **O-kuni wa doko desu ka.**

but

お国はどちらですか。 **O-kuni wa dochira desu ka.**

And although どちら **dochira** can always be used to mean “which

(of two)?”, it can also be used politely to mean “which (of many)?”; that is, as an equivalent for the neutral word どれ **dore**.

It can be used, for example, in such sentences as

“Which (of all these) do you think is best?”
どちらがいいでしょうか。 **Dochira ga ī deshō ka.**

These words (わたくし **watakushi**, いかが **ikaga**, どちら **dochira** etc.) serve to give an air of *politeness* to the language in general.

It is therefore convenient to call them *polite words*.

There are other words, however, which show *respect* specifically to a particular person.

We can therefore distinguish these by calling them *respectful words*.

Polite words, then, raise the general tone of the language, usually out of concern for the impression created on the hearer, that is on the 2nd person.

Respectful words, however, show respect to a specific person who may or may not be the 2nd person.

One such word is 方 **kata**, a respectful equivalent for 人 **hito** “person”.

Both 人 **hito** and 方 **kata** mean “person”, but 方 **kata** shows more respect to the person in question.

Thus, a more respectful equivalent for

“Let’s ask that person/him”
あの人に聞きましょう **Ano hito ni kikimashō**

would be

あの方に聞きましょう。 **Ano kata ni kikimashō.**

Connected in origin with 方 **kata** is the ordinary respectful word for “you” namely あなた **anata**.

This same ending is also found in a respectful equivalent for 誰 **dare** “who?”, namely どなた **donata**.

Both どなた **donata** and 誰 **dare** mean “who?”, but どなた **donata** is more respectful.

Thus, a more respectful alternative for

“Who are you?”
あなたは誰ですか **Anata wa dare desu ka**

would be

あなたはどなたですか **Anata wa donata desu ka**

and a more respectful alternative for

“Who is he?”
あの方は誰ですか **Ano hito wa dare desu ka**

would be

あのかたはどなたですか。 **Ano kata wa donata desu ka.**

But a man would be unlikely to use respectful forms to a boy who telephones asking for his son, and would probably say merely

“Who is it?” 誰ですか。 **Dare desu ka.**

(The showing of respect in such a situation is discussed on pages 22–23.)

A more general way of making respectful words (usually nouns or adjectives) is by using an honorific prefix such as お **o**, ご (御) **go** or, in certain rather archaic expressions, 御 (おん) **on**.

Thus, “your room” could be (あなたの **anata no**) お部屋 **o-heya**;

“the teacher’s research” could be 先生のご研究 **sensei no go-kenkyū**;

and, in a letter in a rather old-fashioned style, “the matter of your request” could be ご依頼の件 **go-irai no ken**.

The honorific prefixes お **o** and ご (御) **go** are now used virtually to the exclusion of all others.

In general, and as might be expected, the native Japanese prefix お **o** is used with native Japanese words;

and the Chinese reading ご (御) **go** is used with words of Chinese origin.

But there are exceptions both ways: for example, although 茶 **cha** “tea”, 邪魔 **jama** “impediment, hindrance” and 客 **kyaku** “guest, visitor” are all words of Chinese origin, they take お **o** as a prefix,

becoming お茶 **o-cha**, お邪魔 **o-jama**, and お客 **o-kyaku** respectively;

while, conversely, ゆっくり **yukkuri** is one of a very few

Japanese words which take the prefix ご **go** to become ごゆっ
くり **go-yukkuri**.

The tendency is for お **o** to spread rather than ご (御) **go**, and some words are at the stage of taking either prefix: 返事 **henji** “reply”, for example, can be ご返事 **go-henji** or, less stiffly and more commonly, お返事 **o-henji**.

The prefix お **o** will not always show respect to a particular person; that is, according to our distinction between (generally) polite and (specifically) respectful words, it will not always indicate a respectful word. Often it has a very general, diffuse effect by forming merely polite words.

In such words as お茶 **o-cha** “tea”, お腹 **o-naka** “stomach”, and おかず **o-kazu** “items of food (eaten with rice)”, for example, the prefix has come to be virtually part of the word itself, used whether the thing in question is associated with a particular person or not.

It is often similarly used with words of western origin to make them more “polite”.

Decades ago, some women would sprinkle their speech with the prefix お **o** quite indiscriminately and use おビール **o-bīru** for “beer” and even おトイレ **o-toire** “toilet”, when these things are not worthy of any special respect. Sometimes today you will hear vestiges of this, for example when a serving lady may say “**o-bīru**” at a Japanese style inn.

The situation can be summed up by saying:

- (i) the honorific prefix used with words of Chinese origin is usually ご **go**.
- (ii) the honorific prefix used with native Japanese words is, with one or two exceptions, お **o**.

- (iii) the honorific prefix used with words of western origin is always お **o**.
- (iv) お **o** is often used to make a person’s speech sound generally more genteel, and does not necessarily involve respect to a particular person.

We have just seen that one way of making respectful words is by using honorific prefixes. Another way is by doing the opposite, that is, by using honorific suffixes.

One such suffix which you will already know very well is さん **san**. Used with a name, etc., it shows respect to the person to whose name or description it is attached.

Thus, 田中さん **Tanaka-san** is usually translated as “Mr. Tanaka” if it refers to a man; as “Mrs. Tanaka” if it refers to a married woman; and as “Miss Tanaka” if it refers to an unmarried woman.

Often, however, **san** will have no separate respectful equivalent in English. It is not always possible to translate さん **san**.

For instance, there will rarely be an acceptable translation for it when it is used after a personal name (次郎さん **Jirō-san**, 百合子さん **Yuriko-san**, etc.), as distinct from a family, and “son” would be the normal translation for both 息子 **musuko** and its respectful equivalent 息子さん **musuko-san**.

Similarly, “daughter” translates both 娘 **musume** and the respectful 娘さん **musume-san** or お嬢さん **ojōsan**;

and “younger sister” both 妹 **imōto** and the respectful 妹さん **imōto-san**.

The same suffix is found in the respectful words for “wife” 奥さん **okusan**;

for “elder sister”, 姉さん **nēsan**;

and for “elder brother”, 兄さん **nīsan**;

but in such cases さん **san** has become an indivisible part of the word.

Some words do not exist without an honorific suffix. (In this book, hyphens have been used throughout to isolate elements which can also exist as independent words; thus, 奥さん **oku-san** and 姉さん **nēsan**, but 息子さん **musuko-san** and 娘さん **musume-san**.)

So far we have looked at words which take *either* an honorific prefix *or* an honorific suffix.

But an important body of respectful words, mostly signifying family relationships, uses *both* an honorific prefix *and* an honorific suffix.

The honorific prefix in nearly all these words is お **o**.

Thus, just as a respectful form for ばあさん **bāsan** “grandmother, old lady” is おばあさん **o-bāsan**,

so one for じいさん **jīsan** “grandfather, old man” is おじいさん **o-jīsan**.

Just as a more respectful form for 姉さん **nēsan** “elder sister” is お姉さん **o-nēsan**,

so one for 兄さん **nīsan** “elder brother” is お兄さん **o-nīsan**.

One for 妹 **imōto** “younger sister” is 妹さん **imōto-san**

and one for 娘さん **musume-san** “daughter” is お嬢さん **ojōsan**.

Just as a respectful form for 母 **haha** “mother” is お母さん **o-kāsan**,

so one for 父 **chichi** “father” is お父さん **o-tōsan**;

and just as a respectful form for 客 **kyaku** and お客 **o-kyaku** “visitor, guest” is お客さん **o-kyaku-san**,

so one for 子 **ko** “child” is お子さん **o-ko-san**.

All these words have respectful forms beginning with お **o** and ending with さん **san**.

But the respectful word for “wife”, 奥さん **okusan**, does not take the usual honorific prefix.

This is no doubt because it already begins with the letter お **o**.

Other such “family” words do not duplicate an initial お **o** in their respectful forms ending in さん **san** either.

For instance, a respectful form for おば **oba** “aunt” is おばさん **oba-san**;

one for おじ **oji** “uncle” is おじさん **oji-san**;

and one for 弟 **otōto** “younger brother” is 弟さん **otōto-san**.

Most respectful forms of “family” words, then, begin with お **o** and end with the suffix さん **san**,

and most of these which can dispense with an initial お **o** have more respectful forms with it:

娘さん **musume-san** “daughter” has お嬢さん **ojōsan**;

姉さん **nēsan** “elder sister” has お姉さん **o-nēsan**;

and 兄さん **nīsan** “elder brother” has お兄さん **o-nīsan**.

The only one which ends in さん **san** but never has an initial お **o** is 息子さん **musuko-san**.

Although 娘さん **musume-san** “daughter” has the more respectful alternative お嬢さん **ojōsan**,

there is no commonly used more respectful alternative for the parallel word 息子さん **musuko-san** “son”.

The ending さん **san** itself has a more respectful form 様 **sama**, which is normally used only after the more respectful forms of words.

Many words can take さん **san**; usually only their more respectful forms take 様 **sama**.

With most words, it is now only the form with both an initial お **o** and a final さん **san** in which this suffix can be replaced by 様 **sama**.

Thus, 様 **sama** cannot replace さん **san** in 姉さん **nēsan**, but in お姉さん **o-nēsan** it can.

Practice

In which of the following words, then, can 様 **sama** be used instead of さん **san**? For each pair, choose “(a)”, “(b)”, or both.

- (a) お兄さん **o-nīsan** “elder brother” (b) 兄さん **nīsan** “elder brother”
- (a) 娘さん **musume-san** “daughter” (b) お嬢さん **ojōsan** “daughter”
- (a) 奥さん **okusan** “wife” (b) お客さん **o-kyaku-san** “visitor, guest”
- (a) 息子さん **musuko-san** “son” (b) お子さん **o-ko-san** “child”
- (a) 弟さん **otōto-san** “younger brother” (b) お父さん **o-tōsan** “father”

Answers:

- (a) お兄様 **o-nīsama**
- (b) お嬢様 **ojōsama**
- Both. (a) 奥様 **okusama**; (b) お客様 **o-kyaku-sama**
- (b) お子様 **o-ko-sama**
- Both. (a) 弟様 **otōto-sama** (b) お父様 **o-tōsama**.
However, **otōto-san** is commonly said.

An exception to this rule is 妹さん **imōto-san** “younger sister” for this can have 様 **sama** instead of さん **san**: 妹様 **imōto-sama**.

Thus, as a more respectful form than 妹さん **imōto-san**, 妹様 **imōto-sama** is possible.

A few other words are too respectful for さん **san** but suitable for use with 様 **sama**.

Such words are ご両親 **go-ryōshin** “(your) parents” which can become, more respectfully, ご両親様 **go-ryōshin-sama**;

the respectful word for “who?”, どなた **donata**, which can become どなた様 **donata-sama**;

and the polite word for “where?” or “which?”, どちら **dochira**, which can become どちら様 **dochira-sama**.

But どちら様 **dochira-sama** is too respectful to be used of something *impersonal*, and is used instead as a personal pronoun meaning “who?”.

Thus, respectful words for “who?” are どなた **donata**, どなた様 **donata-sama**, and どちら様 **dochira-sama**.

Proper nouns which can take さん **san** (e.g. 田中さん **Tanaka-san**) are also respectful enough in themselves to be able to take instead the more respectful 様 **sama**.

If more than usual respect is shown to a person, then, his name will be followed by 様 **sama** rather than by さん **san**.

The Crown Prince, for example, is usually referred to as 皇太子様 **Kōtaishi-sama**.

When speaking about ordinary people, however, people will rarely use anything more than the normally respectful suffix さん **san** after their names.

We should also note here variant forms of さん **san** and 様 **sama** in which the initial **s** changes to **ch**.

Hence, さん **san** becomes ちゃん **chan** and, more politely, 様 **sama** becomes ちゃま **chama**.

These variants are characteristic of a close relationship, usually within a family; and being somewhat childish in character, they are used particularly to and by children.

For example, in talking to his small child, a parent will call the child's uncle おじちゃん **oji-chan** (instead of おじさん **oji-san**) or おじちゃま **oji-chama** (instead of おじ様 **oji-sama**),

and the child's aunt おばちゃん **oba-chan** or おばちゃま **oba-chama**.

Since both terms, like the English “uncle” and “aunt”, can be used of outsiders who are treated as “honorary” uncles or aunts, when visiting a Japanese family you could find yourself referred to as おじちゃん **oji-chan** (if male), おばちゃん **oba-chan** (if female).

An adult will normally use ちゃん **chan** and ちゃま **chama** when talking to a child, and children use them to the exclusion of さん **san** and 様 **sama**.

A child will therefore call his mother お母ちゃん **o-kāchan** or お母ちゃま **okāchama**.

The suffixes ちゃん **chan** and ちゃま **chama** are thus not unlike

the English familiar “-y” ending, おばちゃん **oba-chan** corresponding to “Aunty”, for example, and お母ちゃん **o-kāchan** to “Mommy”.

The two suffixes can be used with personal names, usually in the abbreviated form: e.g.

ゆうじろう **Yūjirō** → ゆうちゃん **Yūchan**;

and with words indicating close family relationships other than 妹 **imōto** and 弟 **otōto**: e.g.

“Daddy” お父ちゃん **o-tōchan**; お父ちやま **otōchama**.

妹 **Imōto** and 弟 **otōto** are exceptional in being family words which do not take ちゃん **chan**/ちやま **chama**. This is because respectful forms of these words are not normally used of people within the family circle.

Instead, personal names are used within the family circle for younger sisters and brothers and these, as we have just seen, can take the suffix ちゃん **chan** or ちやま **chama**.

Thus a boy called ゆうのすけ **Yūnosuke** might refer to his elder sister as (お)姉ちゃん (**o-nēchan**),

and be referred to by her as ゆうちゃん **Yūchan**.

We can now conveniently put the words we have been discussing into a table, arranged with the polite or respectful words in alphabetical order. Go through the table below carefully, line after line, until you feel you know all the words and meanings.

Words in the first two columns with the same meanings have been arranged in an ascending order of respect or formality. The first column contains words of widely differing connotations; but to give some idea of their usage, words used only in brusque or very informal speech have been put in parentheses: (お前 **omae**), and words which, though essentially respectful, are commonly used in neutral-level speech have been put in square brackets: [あなた **anata**].

Neutral (Non-Respectful)	Polite/Respectful	Meaning
おまえ (omae), 君 kimi , [あなた anata]	あなた anata	you
あそこ asoko	あちら achira	(over) there
どこ doko	どちら dochira	where?
どれ dore	どちら dochira	which?
だれ dare	どなた donata , どなた様 donata-sama , どちら様 dochira-sama	who?
親達 (oyatachi), 親 oya , 両親 ryōshin	ご両親 go-ryōshin , ご両親様 go-ryōshin-sama	parents
主人 shujin , 夫 otto	ご主人 go-shujin , ご主人様 go-shujin-sama	husband, master

Neutral (Non-Respectful)	Polite/Respectful	Meaning
どう(ですか) dō (desu ka etc.)	いかが(ですか) ikaga (desu ka etc.)	how (is it? etc.)
妹 imōto	妹さん imōto-san ¹	younger sister
弟 otōto	弟さん otōto-san ¹	younger brother
物 (mono), 人 hito	方 kata	person
ここ koko	こちら kochira	here
息子 musuko	息子さん musuko-san	son
娘 musume	娘さん musume-san, お嬢さん ojōsan ¹	daughter
姉 ane	姉さん nēsan ² , お姉さん o-nēsan ^{1,2}	elder sister
兄 ani	兄さん nīsan ² , お兄さん o-nīsan ^{1,2}	elder brother
plain word	o-, go-, on-	(honorific prefix)
ばあさん bāsan, 祖母 sobo, [おばあさん o-bāsan]	おばあさん o-bāsan ^{1,2}	grandmother, old lady
おば oba	おばさん oba-san ^{1,2}	aunt
じいさん jīsan, 祖父 sofū, [おじいさん o-jīsan]	おじいさん o-jīsan ^{1,2}	grandfather, old man

Neutral (Non-Respectful)	Polite/Respectful	Meaning
おじ oji	おじさん oji-san ^{1,2}	uncle
父さん tōsan, 父 chichi	お父さん o-tōsan ^{1,2}	father
かあさん kāsan, はは haha	おかあさん o-kāsan ^{1,2}	mother
子 ko, 子供 kodomo	お子さん o-ko-san ¹	child
女房 (nyōbō), 家内 kanai	奥さん okusan ¹	wife
客 kyaku, お客 o-kyaku	お客さん o-kyaku-san ¹	visitor, guest
(family name only), 君 -kun ³	さん -san, 様 -sama	(hon. suffix) Mr. etc.
そこ soko	そちら sochira	there
俺 (ore), 僕 boku, 私 watashi	私 watakushi	I

Notes:

- さん -san has 様 -sama as a more formal and respectful alternative in these words (i.e., except for imōto-san, words which also have an initial o).
- さん -san has ちゃん -chan and 様 -sama has ちゃま -chama as rather childish "family" alternatives in these words (i.e. words used in close family relationships).
- Not used by or with reference to women; they use さん -san or 様 -sama (unless referring to their own husbands when names are commonly used without any suffix), and are themselves referred to as さん -san or 様 -sama when called by their family names.

A similar list is given at the end of the book, as Appendix 2, for reference.

Practice

When you are satisfied that you can remember all the equivalents and their meanings, complete the following sentences by adding appropriate neutral or polite/respectful words.

1. A man to a stranger: "Are you Mr. Ishida's elder brother?"

(あなたは)石田 _____ の _____ ですか。

(Anata wa) Ishida- _____ no _____ desu ka.

2. A man to a boy who telephones asking for his son:
"Who is it?"

_____ ですか。

_____ **desu ka.** (cf. page 22)

3. A woman to a neighbor:
"Is this a photograph of your mother?"

これは、(あなたの) _____ のお写真ですか。

Kore wa (anata no) _____ no o-shashin desu ka.
(cf. page 23)

4. Same woman to a delivery boy:
"Where is your young brother?"

(あなたの) _____ はどこにいますか。

(Anata no) _____ wa doko ni imasu ka.
(cf. page 23)

5. A girl to her father:
"Father! Wait a minute, please."

_____ ちょっと待って(ください)。

_____ **! chotto matte (kudasai).**

6. A boy to his younger sister:
"You're only my younger sister, you know!"

ぼくの _____ じゃないか。

Boku no _____ ja nai ka! (cf. pages 17-18)

7. One shop assistant to another:
"The person working with me is hopeless."

私と働いている _____ はダメよ。

Watashi to hataraitte iru _____ wa dame yo.
(cf. pages 20-21)

8. A secretary, introducing members of staff to a new secretary:
"This (person) is our branch manager."

_____ は、この支店の支配人です。

_____ **wa kono shiten no shihainin desu.**
(cf. pages 20-21)

Answers:

1. さん **san**; お兄さん/お兄様 **o-nisan/onisama** (Other appropriate equivalents are given in the above chart, i.e. 様 **sama**, お兄様 **onisama**. Refer back to page 22.)
2. 誰 **Dare**
3. お母さん/お母様 **o-kāsan/okāsama**
4. 弟さん **otōto-san**
5. お父さん **O-tōsan** (or other respectful equivalent; see pages 18–19.)
6. 妹 **imōto**
7. 人 **hito**
8. こちら **Kochira**

The last two practice questions above give typical examples of the respect within a closed circle described on pages 17–22, but it is necessary to modify somewhat the guide rules given there when the closed circle is the family:

- (i) The neutral informality within a family leads to the avoidance of the more elaborate verbal forms of respect (these are dealt with later in the book).
- (ii) Conversely, many respectful nouns (お父さん **o-tōsan**, 兄さん **nisan** etc.) are used all the time—within the closed circle, remember—whether the person referred to is present or not.

Thus, (i) and (ii) together result in a feeling of informality, coupled with respect for the senior members of the family through the use of respectful nouns.

For example:

Mother to daughter:

“Where is your (elder) brother?”

(お)兄さん/(お)兄ちゃんはどこ(ですか)。

(O-)nisan/(O-)nichan wa doko (desu ka).

There are two other apparent peculiarities of the use of respectful nouns in the family situation.

Talking to a servant in his own house, a man will regularly refer to his own wife as 奥さん **okusan**; but this is a closed circle situation affected by the lowly status of the servant, and the psychology behind it is no different from that of the fictional English lord saying to his butler, “James, tell her ladyship the carriage awaits.”

Again, although one does not normally show respect to oneself—in Japanese or in English—people talking to a young child will use respectful words of themselves; but this is no doubt to train the child to use the appropriate word in his own speech and is no different from our saying “Bring it to Daddy”, for which the Japanese might say (using a “family” equivalent for “Daddy”):

お父さんに持って来てね。

(O-)tōsan ni motte kite (ne).

Let’s move on now to our next main situation in which the speaker talks to an outsider about someone connected only with himself.

Practice

1. Which of these diagrams illustrates this situation—the speaker talks to an outsider about someone connected only with himself?

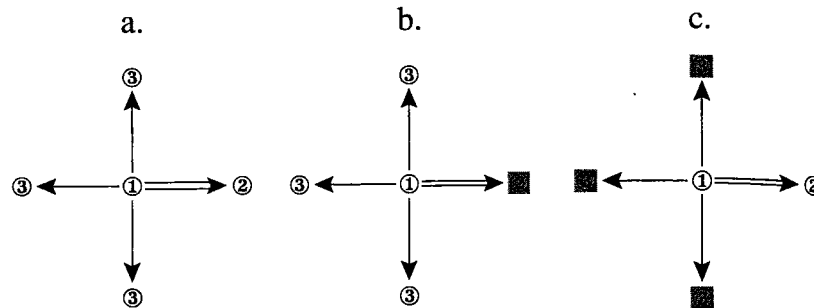

Answer:

1. Diagram b is the correct one for this situation. The language used is neutral (non-respectful) in all cases.

Thus, a student would say to a teacher:

“My father is a butcher.”

(私の)父は肉屋です。

(**Watashi no**) **chichi wa nikuya desu.** (cf. page 22)

A clerk would say to a director of his company:

“My wife is ill.”

(私の)家内は、病気です。

(**Watashi/Watakushi no**) **kanai wa byōki desu.** (cf. page 22)

On to our last basic situation, in which the speaker talks about a 3rd person not connected with either himself or the person addressed.

A woman would say to a group of her friends:

“Who do you think the new Minister of Education will be?”

今度の文部科学大臣は、どなたでしょうか。

Kondo no Monbu Kagaku Daijin wa donata deshō ka.

(Or **どなた様 donata-sama** / **どちら様 dochira-sama** although, in practice, these would hardly be used here about an absent 3rd person; pages 24–25.)

One person to another:

“Is that person over there an artist?”

あの人は絵描きですか。

Ano hito wa e-kaki desu ka. (page 24)

A person introducing someone to his brother:

“This (person) is the headmaster of the middle school.”

この方は、中学校の校長先生です。

Kono kata wa chūgakkō no kōchō-sensei desu. (page 24)

A guest to host, on looking out the window:

“Who is that sweeping the street?”

あの路を掃除しているのは、誰でしょうか。

Ano michi o sōji shite iru no wa dare deshō ka. (cf. page 24)

CHAPTER 3

Honorific Verbs: (a) Standard Forms

Being the simplest form of respect language, respectful nouns and pronouns etc. are often used without any elaborate verbal forms, as we've seen, to provide a modicum of respect in an easy and unobtrusive way.

Respect language is mainly based, however, on special verb forms, which we will learn about now. (They are also listed for your reference in Appendix 3, in ascending order of respect.)

Verbs already familiar to us as いる **iru**, 行く **iku**, 来る **kuru** etc. are "neutral" in feeling, in that they have no overtones of either respect or humility. They are usable in the above plain forms when it is not necessary to show respect to either the person discussed or the person addressed;

and they form the basis of the standard polite conversational language when used with **ます masu** endings to show respect to the person addressed.

The special verb forms which show respect are of two main kinds and achieve their object in different ways.

One way to show respect to the grammatical subject of a verb would be to use a special verb which raises the status of its subject.

Such verbs exist in Japanese and, since they enable the speaker to *honor* their grammatical subjects, we will call them *honorific verbs*.

Since these verbs indicate respect to their subjects, if the person to whom respect is to be shown is *not* the subject, an honorific verb is of no use.

But if he is the person addressed or is in some way concerned in the action of the verb even though he is not its subject, one way to raise his relative status would be to use, on the see-saw principle, a special verb which *lowers* the status of its subject.

Such verbs exist in Japanese and since, in order to raise the relative status of someone else involved or of the person addressed, they *depreciate* the status of their own subjects, we will call them *depreciatory verbs*.

The two main kinds of verb used in Japanese to show respect, then, are the honorific and the depreciatory verbs.

An honorific verb shows respect to its subject by raising his or her status;

and a depreciatory verb lowers/depreciates the status of its subject in order to show respect to someone else.

Most honorific verbs are derived from ordinary “neutral” verbs by adding the honorific prefix *o* to the base of the verb and following this verbal noun by *になる ni naru** (or *なさる nasaru**, particularly in imperative expressions); e.g.

* A raised plus + sign after an inflected word indicates that additional derived forms are to be understood as included with the basic form cited; thus *da*+ can signify *だ da*, *です desu*, *だった datta*, *だろう darō* etc. as appropriate.

休む *yasumu*+ → お休みになる *o-yasumi ni naru*+

This standard honorific form we can therefore call the *お o + base + になる ni naru* construction.

There are only two groups of verbs which do **not** use this construction for their honorific forms:

- (i) verbs of the 連絡/研究する *renraku/kenkyū suru*+ type, which have instead ご連絡なさる *go-renraku nasaru*+ “make contact”, ご研究なさる *go-kenkyū nasaru*+ “study” etc.

Hence, an immigration official would say to a visiting diplomat: “How would it be if you were to contact the embassy, sir?”
大使館にご連絡なさったらいかがでしょうか。
Taishikan ni go-renraku nasattara ikaga deshō ka.

A student would say to a teacher:

“Dr. Tanaka seems to study all day and every day, doesn’t he.”

田中博士は、毎日朝から晩までご研究なさるようですね。

Tanaka hakase wa mainichi asa kara ban made go-kenkyū nasaru yō desu ne.

And a woman would say to a neighbor:

“Has your husband discussed it with his father?”

ご主人は、お父様とご相談なさいましたか。

Go-shujin wa o-tōsama to go-sōdan nasaimashita ka.

But the neighbor’s reply, “No, I don’t think he has yet,” would be
いいえ、まだ相談していません。

Iie, mada sōdan shite inai to omoimasu. (cf. page 22)

(ii) the following twelve verbs, which have special words as their honorifics:

Neutral	Honorific
だ da + “be” (animate subjects only)	でいらっしゃる de irassharu +, でおいでのなる de oide ni naru +
いる iru + “be (present)”	いらっしゃる irassharu +, おいでのなる oide ni naru +
行く iku + “go” 来る kuru + “come”	いらっしゃる irassharu +, おいでのなる oide ni naru +, いらっしゃる irassharu +, おいでのなる oide ni naru +, おこしになる okoshi ni raru +, お見えになる o-mie ni naru +, (“put in an appearance” only)
着る kiru + “wear” only	召す mesu +, お召しになる o-meshi ni naru +
くれる kureru + “condescend”	くださる kudasaru +
見る miru + “see”	ごらんになる goran ni naru +
死ぬ shinu + “die”	お亡くなりになる o-nakunari ni naru +
知る shiru + “know”	お知りになる o-shiri ni naru +, ご存じ go-zonji +
する suru + “do”	なさる nasaru +
食べる taberu + “eat”	あがる agaru +, お食べになる o-tabe ni naru +, 召し上がる meshi-agaru +
言う iu/yū + “say”	おっしゃる ossharu +

Practice

Read through the above chart several times until you can remember all, or nearly all, the honorific equivalents. Then, referring back to the chart where necessary, complete the following sentences.

1. Hotel reception clerk to guest:
“Who are you, sir?”

どなた(様)/ _____ 様 _____ しゃいますか。

Donata(-sama)/ _____ -sama _____ shaimasu ka.

2. Hotel maid to guest:
“Will you wear this *yukata* (cotton robe), sir?”

この浴衣をお _____ か。

Kono yukata o o- _____ ka.

3. One female student to another:
“I don’t think the teacher’s in his room.”

先生は、お部屋に _____ らないと思います。

Sensei wa o-heya ni _____ ranai to omoimasu.

4. A student to teacher:
“Professor Hasegawa gave me this book. Please look at it.”

長谷川教授は、この本を _____ ました。

Hasegawa kyōju wa kono hon o _____ mashita.

____、____ てください。

____, _____ te kudasai.

Answers:

1. どちら **Dochira**; でいらっ **de iras-**
2. 召しになります **meshi ni narimasu**
3. いらっしや **irassha-**
4. ください **kudasai**; **Dōzo**, どうぞ、ごらんになっ; **Dōzo**,
goran ni nat-

Since an honorific verb shows respect to its grammatical subject, the two you completed in the above practice sentences show respect to different people: the first is respectful to the person addressed and the second to the second person.

Continuing, then, with our examples, we might have a woman say to a local official:

“I hear the (town) mayor has died.”
社長は、お亡くなりになったそうです。
Shichō wa o-nakunari ni natta sō desu.

A mother, to another guest at the same hotel:

“I suppose you don’t know where my child has gone, do you?”
私の子供がどこへ行ったかご存じ(ない)でしょうか。
Watakushi no kodomo ga doko e itta ka go-zonji (nai)
deshō ne.

A company employee to a director returned from abroad:
“Where did you travel in Europe, sir?”
ヨーロッパのどちらをご旅行なさいましたか。
Yōroppa no dochira o go-ryokō nasaimashita ka.

A waitress to a customer:

“What will you (have to) eat, sir?”
何を召し上がりますか。
Nani o meshiagarimasu ka.

A girl to her uncle:

“Please don’t say things like that.”
そんなことは、おっしゃらないでください。
Sonna koto wa ossharanai de kudasai.

The above two groups of verbs do not use the standard honorific construction at all; but three verbs have special words as honorifics *in addition* to the standard お o + base + になる ni naru construction:

Neutral	Honorific
飲む nomu ⁺ “drink”	お飲みになる o-nomi ni naru ⁺ , あがる agaru ⁺ , 召し上がる meshiagaru
思う omou ⁺ “think, feel”	お思いになる ōmoi ni naru ⁺ , 思し召す oboshimesu ⁺
呼ぶ yobu ⁺ “call, send for”	お呼びになる o-yobi ni naru ⁺ , 召す mesu ⁺ , お召しになる o-meshi ni naru ⁺
思し召す Oboshimesu ⁺ (for 思う omou ⁺), however, will now only be seen occasionally in letters; and 召す mesu ⁺ and related forms are little used as equivalents for 呼ぶ yobu ⁺ in the honorific expressions we have met so far.	

Thus, a nurse would say to an important patient:

“Drink this medicine, please.”

この薬をお飲み(になって)ください。

Kono kusuri o o-nomi (ni natte) kudasai.

A chauffeur would say to an employer:

“Don’t you think the engine’s having trouble, sir?”

エンジンの具合がちょっと悪いとお思いになりませんか。

Enjin no guai ga chotto warui to ōmoi ni narimasen ka.

And a maid would say to her employer:

“Did you send for the doctor, ma’am?”

奥さん、お医者さんをお呼びになりましたか。

Okusan, o-isha-san o o-yobi ni narimashita ka.

You will have noticed that some verbs share the same honorifics. The context usually removes ambiguity, but note in passing that *いらっしゃいました/お出でになりました irasshaimashita/oide ni narimashita*, for example, can be equivalent to the neutral-verb forms:

来ました Kimashita	“[He] came”
行きました Ikimashita	“[He] went”, or
いました Imashita	“[He] was present”.

Also note that *これをあがって/召し上がってください Kore o agatte/meshiagatte kudasai* can mean either

“Please eat this” or “Please drink this”.

The above verbs, then, have special honorific equivalents. All others use as their honorifics only the standard *お o + base + になる ni naru* construction, e.g.

待つ **matsu*** → お待ちになる **o-machi ni naru*** “wait”.

Practice

Give English meanings for the honorific words in the following sentences.

1. お父さんは、何時にお帰りになるでしょうか。
O-tōsan wa nanji ni o-kaeri ni naru deshō ka.

“When do you think your father will _____?”

2. ご興味がおありますか。
Go-kyōmi ga o-ari desu ka.

“Do _____ any interest in it?”

3. その本は、もうお読みになりましたか。
Sono hon wa mō o-yomi ni narimashita ka.

“_____ that book now?”

4. お驚きになったでしょう。
O-odoroki ni natta deshō.

“No doubt _____ surprised?”

5. 朝は、何時ごろお起きになるんですか。
Asa wa nanjigoro o-oki ni narun’ desu ka.

“About what time _____ in the morning?”

Answers:

- | | |
|------------------|------------------|
| 1. return | 4. you were |
| 2. you have | 5. do you get up |
| 3. Have you read | |

Practice

Now supply appropriate honorific verbs in the following sentences.

1. "Won't you please show me that picture?"

その絵を見せてくださいませんか。

Sono e o misete kudasaimasen ka.

その絵をお _____ くださいませんか。

Sono e o o _____ kudasaimasen ka.

2. "Hasn't your elder brother had that kind of experience?"

お兄さんには、そのような経験がありませんか。

O-niisan ni wa, sō no yō na keiken ga arimasen ka.

お兄様には、そのようなご経験が _____。

O-niisama ni wa, sō no yō na go-keiken ga _____ ka.

3. "Yours is an old family, isn't it?"

お宅は、旧家ですね。

O-taku wa, kyūka desu ne.

お宅は、旧家で _____ ね。

O-taku wa, kyūka de _____ ne.

4. "You'll be able to see it if you go outside."

外へ出ると、見られるでしょう。

Soto e deru to, mirareru deshō.

外へ _____ と、見られるでしょう。

Soto e _____ to, mirareru deshō.

5. "Why won't you see him?"

なぜあの方にお _____ か。

Naze ano kata ni o- _____ ka.

6. "I think the guest received a letter yesterday."

お客様は、昨日お手紙を _____ と思います。

O-kyaku-sama wa kinō o-tegami o _____ to omoimasu. (Use 受け取る *uketoru*+ "receive")

Answers:

- 見せになって **-mise ni natte**
- おありになりませんか **o-ari ni narimasen**
- いらっしゃいます **irasshaimasu** (Remember that **desu**+ is usually a contraction of **de gozaimasu**+. This example is taken from a modern novel but, as will be explained later, **de irassharu**+ is in fact quite rare.)
- お出になる **o-de ni naru** (In this sentence, the neutral-level 見られる **mirareru** is somewhat inconsistent with the honorific お出になる **o-de ni naru**. Such inconsistency of levels of politeness is by no means uncommon, but the

same sentence with honorific verbs in both parts would be:
外へお出になると、ご覧になれるでしょう。
Soto e o-de ni naru to, goran ni nareru deshō.

5. 会いになりません **ai ni narimasen** (Remember that 見る **miru**⁺ and related verbs mean literally “see” and do not now cover the English use of “see” = “meet”.)
6. お受け取りになった **o-uketori ni natta**

受け取る **Uketoru**⁺ means simply “receive”, but もらう **morau**⁺ means “receive (from a superior)”. (Note that the おもらいになる **o-morai ni naru** construction is not often used in normal conversation.)

お客様は、お手紙をお受け取りになりました。
O-kyaku-sama wa o-tegami o o-uketori ni narimashita.

お客様は、お手紙をおもらいになりました。
O-kyaku-sama wa o-tegami o o-morai ni narimashita.

おもらいになる **O-morai ni naru**⁺ is the appropriate honorific verb if the “giver” is clearly senior to the “receiver.”

For example, government clerk to department head:

“Did you receive the Minister’s letter, sir?”
大臣のお手紙をおもらいになりましたか。
Daijin no o-tegami o o-morai ni narimashita ka.

And the following sentence also uses the honorific verb which fits the situation:

“Did you receive my letter, sir?”
私の手紙をお受け取りになりましたか。
Watakushi no (o-)tegami o o-uketori ni narimashita ka.

Review these additional examples of honorifics:

“Is your wife going to the theater too?”
奥様も芝居へいらっしゃいます/おいでになりますか。
Okusama mo shibai e irasshaimasu/oide ni narimasu ka.

“Are you coming too?”
あなたも、おいでになりますか。
Anata mo oide ni narimasu ka.

“Your elder brother isn’t here, is he?”
お兄様は、こちらにはいらっしゃいませんね。
O-niisama wa kochira ni wa irasshaimasen ne.

“Have you met my wife?”
(私の)家内にお会いになったことがありますか。
(**Watashi/Watakushi no**) **kanai ni o-ai ni natta koto ga arimasu ka.**

“Please don’t think badly of me.”
私のことを悪くお思いにならないでください。
Watakushi no koto o waruku o-omoi ni naranai de kudasai.

Another standard honorific is the (ら)れる (**ra**)**reru**⁺ passive form of the neutral verb. When used as an honorific, this form replaces the ordinary active verb without any change of particles.

Thus,

“The guest went out”

お客が出ました **O-kyaku ga demashita**

could become

お客様が出られました。

O-kyaku(-sama) ga deraremashita.

“Did your father ask him to do so?”

お父さんは、そうするように頼みましたか

O-tōsan wa sō suru yō ni tanomimashita ka

could become

お父様は、そうするように頼まれましたか。

O-tōsama wa sō suru yō ni tanomaremashita ka.

And “I suppose you’re still working for the same company?”

同じ会社に勤めているでしょう

Onaji kaisha ni tsutomete iru deshō

could become

同じ会社に勤めていられるでしょう。

Onaji kaisha ni tsutomete irareru deshō.

In ordinary circumstances, however, this form is not used as much as the other standard honorifics; don’t choose it over them. There are several reasons for this: not all verbs are commonly used in this way; it can be ambiguous, since it is the same as the passive/

potential form; and particular care must be taken to distinguish it from the “indirect passive” form in which the agent who performs the action is followed by に **ni** and the implication is one of “being caused trouble by”. For example,

友達に頼られました

Tomodachi ni tanomaremashita “I was asked by my friend”

can imply

“I was (inconvenienced by being) asked by my friend”

and can convey the same feeling of annoyance and trouble as

警察に運転免許を取られました

Keisatsu ni unten menkyo o toraremashita

“I had my driving license taken away by the police”,

or “I was caught in the rain”, that is

“I was fallen-on by rain.”

雨に降られました。 **Ame ni furaremashita.**

You will certainly encounter passives used as honorifics, however, so keep that possibility in mind.

Honorific Verbs: (b) Miscellaneous Forms

The special verbs, the お o + base + になる ni naru construction, and the passive form, are all full honorific forms; but a shorter and simpler honorific form is also commonly used on less formal occasions, normally in conjunction with the miscellaneous polite and respectful words (奥さん okusan, お父さん o-tōsan, どなた donata etc.) we discussed earlier. It consists simply of the honorific verbal nouns found before なさる nasaru⁺ or になる ni naru⁺ in honorific constructions (ご連絡 go-renraku, お聞き o-kiki, お待ち o-machi etc.) used with だ da⁺. For example,

いつお発ちですか。 **Itsu o-tachi desu ka.**

“When is your leaving?”, that is, “When will you be/are you leaving?”

Similarly,

“It’s a worry for your wife, isn’t it?”

奥様は、ご心配です/でしょうね。

Okusama wa go-shinpai desu/deshō ne.

“I suppose you understand now?”

もう、お分かりでしょう。 **Mō o-wakari deshō.**

“What time did you finish working last night?”

昨夜は、何時までお仕事でしたか。

Yūbe wa nanji made o-shigoto deshita ka.

“Is the headmaster going home now?”

校長先生は、もうお帰りですか。

Kōchō-sensei wa mō o-kaeri desu ka.

“I understand he was in consultation with the university president then.”

その時は、大学総長とご相談中だったそうです。

Sono toki wa daigaku sōchō to go-sōdan chū datta sō desu.

“I think your father’s waiting.”

お父さん/お父様は、お待ちだと思います。

O-tōsan/Otōsama wa o-machi da to omoimasu.

(From here on in the Practice sections, when **さん san** and **様 sama** are alternatives, use **さん san** as the standard suffix.)

“Is your mother in?”

お母さん/お母様は、おいでです/でしょうか。

O-kāsan/O-kāsama wa oide desu/deshō ka.

Used with respectful nouns, pronouns etc., this form provides a useful honorific level that is adequate for many occasions.

Sometimes, however, this form has its politeness level raised back to that of a full honorific by the replacement of **da**⁺ by an honorific equivalent used with animate subjects, **でいらっしゃる de irassharu**⁺.

For example, the question

どうしてご存じなんですか。

Dō shite go-zonji nan desu ka.

“How do you know?”

could be put at the full honorific level in the form:

どうしてご存じでいらっしゃいますか。

Dō shite go-zonji de irasshaimasu ka.

Similarly, at the full honorific level,

“When will you be leaving?” can be

いつお発ちでいらっしゃいますか。

Itsu o-tachi de irasshaimasu ka.

In our examples so far we have used a “**ます masu** level” of politeness, because this is the type of Japanese with which you are most familiar; but it must be emphasized that this use of **ます masu**⁺ shows politeness to the person addressed and *serves no other purpose*.

Consequently, if the person being shown respect by the use of an honorific verb (i.e. its subject) is not the person addressed, **ます masu**⁺ endings will be used only if respect is to be shown to the 2nd person also. The examples of honorifics given above assumed this, and a polite **ます masu** level of language was used; but if respect to the 2nd person is *not* necessary, **ます masu**⁺ endings need not be used.

One student talking to another, for example, might dispense with such formality towards her friend and say, for

“The teacher hasn’t turned up yet, has he?” *not*:

先生は、まだお見えになりませんね

Sensei wa mada o-mie ni narimasen ne

but

先生は、まだお見えにならないね。

Sensei wa mada o-mie ni naranai ne.

It would seem to follow from this that, when the person addressed is the subject of an honorific verb, a polite **ます masu⁺** ending must necessarily be used—and normally that's true:

“Won't you go with us, sir?”
 (ご)一緒にいらっしやいませんか。
(Go-)issho ni irasshaimasen ka.

On occasions, however, honorific forms may be used about the person addressed *without* any complementary **ます masu⁺** endings. This usage, found much more widely among women than men, conveys a feeling of respect (because of the honorific) combined with friendly familiarity (because of the plain form of the verb).

Thus, one woman might talk to a younger one in this way and say for

“Won't you come with us?” *not*:
 (ご)一緒にいらっしやいません
(Go-)issho ni irasshaimasen

but

(ご)一緒にいらっしやらない。
(Go-)issho ni irassharanai.

Similarly,

どんなものをお買いになったの。
Donna mono o o-kai ni natta no.
 “What kind of thing did you buy?”

(の **No** is here an interrogative particle; it is much softer and more friendly in feeling than **か ka**, which would be out of place in such a sentence.)

“What are you looking at?”
 何を見ていらっしやるの。
Nani o mite irassharu no.

or

何をご覧になっているの。
Nani o goran ni natte iru no.

“Aren't you Mr. Tanaka's private secretary?”
 田中さんの秘書ではいらっしやらないの。
Tanaka-san no hisho de wa irassharanai no.

Now's the time for a brief mention of a modification of the standard **お o + base + になる ni naru** honorific construction.

This consists of reducing the **になる ni naru⁺** to the neutral **する suru⁺** and using the resulting **お o + base + する suru** construction as a kind of informal honorific.

A mother talking to her small son, for example, might say for “Sit down and drink” *not*:
 お座りになってお飲みなさい
O-suwari ni natte o-nomi nasai

but

お座りして(お)飲みなさい。
O-suwari shite (o-)nomi nasai.

Similarly, for

“Just go and ask him, would you?” you might hear not:

ちょっと、お聞きになっていらっしゃい

Chotto o-kiki ni natte irasshai

but

ちょっと、お聞きしていらっしゃい。

Chotto o-kiki shite irasshai.

You will encounter this usage sooner or later, but it is mentioned here only for information. It's not usually recommended for intermediate learners' use, because it is easily confused with a depreciatory form, as we shall soon see.

Before leaving honorific verbs, let's quickly look at 召す **mesu**⁺ and お召しになる **o-meshi ni naru**⁺. These verbs have a wide range of possible meanings but, being extremely honorific, they are in fact very restricted in their use. Their most common use is as the special, and the only, honorifics for 着る **kiru**⁺ “wear” as we have already seen (page 55, #2).

It is also possible for 召す **mesu**⁺ and お召しになる **o-meshi ni naru**⁺ to be used as alternative honorifics (instead of the お **o** + base + になる **ni naru**⁺ forms of the appropriate neutral verbs) in a few expressions in which their meaning often seems to center on the idea of “avail oneself of, take to oneself”.

“Will you wear a *yukata* (cotton robe), sir?”

浴衣ををお召しになりますか。

Yukata o o-meshi ni narimasu ka.

“You will catch a cold, sir!”

お風邪を召しますよ。

O-kaze o meshimasu yo.

“The emperor will ride in that train.”

天皇陛下は、あの列車にお召しになります。

Tennō heika wa ano ressha ni o-meshi ni narimasu.

Hence:

あれは、お召し列車です。

Are wa o-meshi ressha desu.

“That is the emperor's train.”

The last use we need to consider is お気に召す **o-ki ni mesu**⁺ which is used as an honorific for 気に入る **ki ni iru**⁺ “be to one's liking”:

“I think you will like this room, sir.”

この部屋は、お気に召すと思います。

Kono heya wa o-ki ni mesu to omoimasu.

Note, however, that in this expression (and in the alternative お気に召す **o-ki ni mesu**⁺, which uses the passive as the honorific) respect is intended not for the grammatical subject of the verb (as is usually the case with honorific verbs), but, by a slight extension, for the person concerned in the “liking”.

The same slightly extended use may be found with おありになる **o-ari ni naru**⁺ when it means “have” (see, for example, page 59, #2 and page 60, #2).

Depreciatory Verbs: (a) Standard Forms

Let's now leave the honorifics and consider the other main group of verbs used in respect language, the depreciatory verbs.

These, remember, show respect to a person who is addressed or who is involved in the action of the verb without being its subject, by lowering the status of the subject. (cf. page 52)

The subject whose status is lowered to show respect to another person is nearly always the speaker or writer, or a close associate of his.

The person to whom respect is intended, however, may be either a 2nd or a 3rd person.

Since respect is more necessary when talking directly *to* a person than when only talking *about* him, most respect forms are directed at the 2nd person.

Depreciatory forms are like honorifics in this. They are used mostly to show respect to the 2nd person; but they are sometimes used to show respect to an exalted person when he is not being addressed.

We will deal later with certain special depreciatory forms which are so humble that they are used *only* to the 2nd person.

The depreciatory forms discussed in this section are those that can reasonably be used to show respect to either the 2nd or 3rd person.

Remember, though, that this use, like that of respect language in general, will vary according to the individual and the situation in which he finds himself.

We saw that although, for their *honorific* forms, some verbs use special honorific verbs not derived from themselves, and most verbs can use their passive forms, the standard honorific construction was お o + base + になる ni naru+.

There is likewise a standard *depreciatory* construction used by most verbs: お o + base + する/いたす suru+/itasu+.

Thus,

待つ **matsu** “wait” → お待ちする/いたす **o-machi suru/itasu**,

and similarly,

願う **negau** “request” → お願いする/いたす **o-negi suru/itasu**.

いたす **Itasu**+ being itself a depreciatory for する **suru**+, the お o + base + いたす **itasu**+ form is more depreciatory than the お o + base + する **suru**+ one.

As we saw, two groups of verbs do not use the standard *honorific* construction: those of the 連絡する **renraku suru** type, and those which use special forms instead.

There are two corresponding groups of exceptions to the standard depreciatory construction:

- (i) 連絡 **renraku** etc. する **suru**+ becomes ご連絡 **go-renraku** etc. する/いたす **suru+/itasu**+. This exactly parallels the standard お o + base + する/いたす **suru+/itasu**+ depreciatory construction,

but note that these verbs must, like 連絡する **renraku suru** “contact” and 相談する **sōdan suru** “discuss”, involve more than one person.

Practice

Which of the following words, then, belong to this class?

- 勉強する **benkyō suru** “study”
- 返事する **henji suru** “answer”
- 散歩する **sanpo suru** “walk”
- 到着する **tōchaku suru** “arrive”

Answer:

- The answer is b. (お返事する/いたす **o-henji suru/itasu**)

(ii) the following verbs which have special words as their depreciatories:

Neutral	Depreciatory
行く <i>iku</i> + “go” 来る <i>kuru</i> + “come”	伺う <i>ukagau</i> + 参る <i>mairu</i> +
言う <i>iu/yū</i> + “say”	申す <i>mōsu</i> + 申し上げる <i>mōshiageru</i> +
する <i>suru</i> + “do”	(する <i>suru</i> +), いたす <i>itasu</i> +
もらう <i>morau</i> + “receive” 飲む <i>nomu</i> + “drink” 食べる <i>taberu</i> + “eat”	いただく <i>itadaku</i> + 頂戴する/いたす <i>chōdai suru/itasu</i> +
見る <i>miru</i> + “see”	拝見する/いたす <i>haiken suru/itasu</i> +
見せる <i>miseru</i> + “show”	お見せする <i>o-mise suru</i> + お目にかける <i>o-me ni kakeru</i> + ご覧に入れる <i>goran ni ireru</i> +
思う <i>omou</i> + “think, feel” 知る <i>shiru</i> + “know”	存じます <i>zonjimasu</i> + 存じる <i>zonjiu</i> + 存じ上げる <i>zonjiageru</i> +
やる <i>yaru</i> + “give” only	差し上げる <i>sashiageru</i> +
あげる <i>ageru</i> + “give” only	差し上げる <i>sashiageru</i> +
Note: as in all similar lists and tables, alternative words with the same meaning are arranged here in an ascending order of respect.	

Practice

After you learn the above depreciatory equivalents, use them to complete the following sentences.

1. “Let’s go to the gentlemen’s house, shall we?”

あの _____ のお宅へ _____ ね。

Ano _____ no o-taku e _____ ne.

2. “I told the Minister I had no intention of doing so, but...”

大臣にそのように _____ つもりはないと _____ が...

Daijin ni sono yō ni _____ tsumori wa nai to _____ ga...

3. “I have been to see the famous garden at the temple.”

お寺の有名なお庭を _____ してきました。

O-tera no yūmei na o-niwa o _____ shite kimashita.

4. “I received something very good from the head of the company.”

社長から立派な物を _____ 。

Shachō kara rippa na mono o _____ .

Answers:

1. 方 **kata**; 参りましょう **mairimashō**
2. する/いたす **suru/itasu**; 申しあげました **mōshiagemashita**
3. 拝見 **haiken**
4. 頂きました **itadakimashita**

In addition to the above two groups which deviate from the standard depreciatory construction, the following verbs have no depreciatory equivalents used to show respect to a 3rd person, the ordinary neutral forms being kept instead. (All have depreciatory equivalents used only to a 2nd person, but these don't concern us yet.)

Neutral	Depreciatory
だ da+ "be"	(だ da+)
ある aru+ "exist"	(ある aru+)
いる iru+ "be (present)"	(いる iru+)
勉強 benkyō etc. する suru+ "study" etc.	(勉強 benkyō etc. する suru+)
死ぬ shinu+ "die"	(亡くなる nakunaru+)
なくなる nakunaru+ "disappear"	(なくなる nakunaru+)

Hence,

"I told Dr. Maeda that I was a student."

前田先生に私は学生だと申しあげました。

Maeda sensei ni watashi wa gakusei da to mōshiagemashita.

And, "I explained to the Minister that I shall not be here tomorrow."

大臣に、明日(私)はおりませんと説明いたしました。

Daijin ni, ashita (watakushi) wa orimasen to setsumei itashimashita.

In the 勉強する **benkyō suru** type of verb included here, no one is involved but the subject.

Distinguish this from the 連絡する **renraku suru** type of (i) above, in which some other person is necessarily involved.

We've seen that, since the action of an *honorific* verb is performed by the person to whom respect is being shown, both types naturally use an honorific prefix (ご **go** or お **o**) and the verb なさる **nasaru+**.

For example, the honorific form of the Japanese verb for "(to) study" is ご勉強なさる **go-benkyō nasaru+**, and for "make contact" is ご連絡なさる **go-renraku nasaru+**.

In the depreciatory forms, the subject is by definition lowly in status. Understandably, therefore, an honorific prefix can only be used with these words if the person being shown respect is involved when the action is carried out by the humble subject.

Thus, it makes sense to say ご連絡する/いたす **go-renraku suru+/itasu+**, literally "I will make (する **suru**)/will humbly make (いたす **itasu**) contact with you/him (ご連絡 **go-renraku**)";

but one cannot use an honorific prefix with 勉強 **benkyō** etc. in a depreciatory construction because the actions signified by such words involve no one but their subjects.

In other words, an honorific prefix is only appropriate with these words if the person being shown respect performs/does the action himself (when an honorific construction is used),

or if he is in some way involved in the action when it is performed by another, “lowly” person (in a depreciatory construction).

There are a few understandable exceptions. In the case of 失礼 *shitsurei* (する *suru*+ “do something rude”, hence often “take one’s leave”), which necessarily involves more than one person, the meaning makes an honorific prefix inappropriate; and most words beginning with 拝 *hai* “humble” (e.g. 拝見 *haiken* “(humble) seeing”) are felt to be respectful enough already.

Thus, some words such as 失礼 *shitsurei* and 拝見 *haiken* never take an honorific prefix.

Hence, “I would like to talk things over with him”

あの方とご相談したいと思います

Ano kata to go-sōdan shitai to omoimasu

and “I intend to contact the ambassador as quickly as possible.”

できるだけ早く大使にご連絡するつもりです。

Dekiru dake hayaku taishi ni go-renraku suru tsumori desu.

But “I studied in the library all day long”

朝から晩まで図書室で勉強しました

Asa kara ban made toshoshitsu de benkyō shimashita

and “I walk around the Hibiya park every morning.”

毎朝日比谷公園を散歩します。

Maiasa Hibiya kōen o sanpo shimasu.

The verbs in the above groups do not use the standard depreciatory construction at all. Some other verbs use special verbs as depreciatories *in addition to* the standard お *o* + base + する *suru*/いたす *itasu* constructions.

Neutral	Depreciatory
会う <i>au</i> + “meet”	お会いする/いたす o-ai suru+/itasu+ , お目にかかる o-me ni kakaru+ “meet (person)” only
借りる <i>kariru</i> + “borrow”	お借りする/いたす o-kari suru+/itasu+ , 拝借する/いたす haishaku suru+/itasu+
聞く <i>kiku</i> +, 尋ねる <i>tazuneru</i> “ask, hear” 訪ねる <i>tazuneru</i> + “inquire, visit”	伺う ukagau+ , お聞きする/いたす o-kiki suru+/itasu+ , お尋ねする/いたす o-tazume suru+/itasu+ , お伺いする/いたす o-ukagi suru+/itasu+ , (承る <i>uketamawaru</i> = 聞く <i>kiku</i> + “hear” only)

Practice

Read through the above chart carefully and then complete these sentences, referring back to the chart if necessary.

1. あの方に伺いましょう。

Ano kata ni ukagaimashō = the neutral

あの人に _____ / _____。

Ano hito ni _____ / _____.

“Let’s ask/inquire of him.”

2. あの人の言う事を伺いましょう。

Ano hito no iu/yū koto o ukagaimashō = the neutral

あの人の言う事を _____。

Ano hito no iu/yū koto o _____.

“Let’s hear him/what he has to say.”

3. あの人の所に/へ伺いましょう。

Ano hito no tokoro ni/e ukagaimashō = the neutral

あの人を _____。

Ano hito o _____.

“Let’s visit him/his place.”

Answers:

1. 聞きましょう/尋ねましょう **kikimashō/tazunemashō**
2. 聞きましょう **kikimashō**
3. 訪ねましょう **tazunemashō** (Note that, in the sense of “visit”, 伺う **ukagau**⁺ is used differently from 訪ねる **tazuneru**⁺ to distinguish it from 人を伺う **hito o ukagau**⁺ “watch for/spy on a person”).

But since 聞く **kiku**⁺ and 尋ねる **tazuneru**⁺ have other equivalents more depreciatory than 伺う **ukagau**⁺, more depreciatory forms of the sentence

あの方に伺いました

Ano kata ni ukagaimashita

would be:

あの方にお聞き/お尋ね/お伺いしました。

Ano kata ni o-kiki/o-tazune/o-ukagai shimashita.

“I asked/inquired of him.”

Similarly, a more depreciatory equivalent for

お借りしました

O-kari shimashita

“I borrowed [it from him]”

拝借しました。

Haishaku shimashita.

And for

お会いしたことがあります

O-ai shita koto ga arimasu

“I have met [him] before”,

a more depreciatory equivalent is

お目にかかったことがあります。

O-me ni kakatta koto ga arimasu.

Verbs other than those in the above groups use *only* standard お o + base + する/いたす **suru/itasu** construction as depreciatories to show respect to a person involved in the action in some way; e.g. お読みする/いたす **o-yomi suru+/itasu+**, お待ちする/いたす **o-machi suru+/itasu+**.

It must be emphasized—again, since we have seen exactly the same thing with (ご)連絡 (**go-**)**renraku** etc. する/いたす **suru+/itasu+**—that the other person being shown respect must be involved in some way in the action of a verb before the use of a depreciatory form is possible. If no other person is involved, an ordinary neutral form is used; e.g. 読む **yomu+**, 待つ **matsu+**.

The following examples illustrate the extent of “involvement” necessary before a depreciatory form can be used.

A student, asked if she had read *a book she had borrowed from her teacher*, might express respect for the teacher by replying to him:

ええ、お読みしました。

Ee, o-yomi shimashita.

If, however, she was asked if she had read *a book of her own*, which someone had seen her carrying, she could only reply with some such neutral verb form as

ええ、読みました。

Ee, yomimashita.

Depreciatory forms are thus sometimes used to show respect to a 3rd person, but they are much more often used when the other person involved is the person addressed (the 2nd person) and respect is being shown to him:

An author sees a book of his in a friend's bookcase and asks if the friend has read it. Since he, the author, is “involved” in the reading to the extent of having made it possible, the friend could express respect to him by using a depreciatory form. He might reply, then:

ええ、お読みしました。

Ee, o-yomi shimashita.

Or, more humbly still:

ええ、お読みいたしました。

Ee, o-yomi itashimashita.

Similarly, if someone finds a list of appointments on his desk and asks his assistant if he has written it out for him, the reply could be either

ええ、私がお書きしました

Ee, watashi ga o-kaki shimashita;

or, if he had not written it out,

いいえ、私はお書きしませんでした。

Iie, watashi wa o-kaki shimasen deshita.

But if the man sees some notes belonging to his assistant and asks if he wrote them, the reply could only be in a non-depreciatory form such as

ええ、私が書きました。

Ee, watashi ga kakimashita.

Asked if he would like some coffee, a guest might reply respectfully

ええ、いただきます。

Ee, itadakimasu.

But if he was asked, as a general question, whether he drank coffee, he would reply either

ええ、飲みます

Ee, nomimasu

or

いいえ、飲みません。

Iie, nomimasen.

いいえ、結構です。

Iie, kekkōdesu.

Similarly, if a doctor rushes to see someone who has drunk poison, the patient could only admit to this by using an ordinary, non-depreciatory form and say

ええ、飲みません。

Ee, nomimasen.

But if the doctor asks him the next day whether he had safely received the medicine he sent to him, the patient could show his gratitude or respect by replying

ええ、いただきました。

Ee, itadakimashita.

Practice

Consider the following situations, and decide on the best response.

1. On being asked if he had seen a new film, a person replies:

ええ、拝見しました。

Ee, haiken shimashita.

Would the questioner be

- a. the director of the film

or

- b. an ordinary friend thinking of inviting him to see it?

2. Someone says

いつかあの方にお会いしたことがあると思います。

Itsu ka ano kata ni o-ai shita koto ga aru to omoimasu.

“I think I have met that person at some time.”

The fact that “that person” is considered important enough to be shown great respect is clear from the use of which word(s)?

3. Since the person referred to in the above sentence is a 3rd person out of hearing, however, the sentence would more commonly be in neutral form throughout. Fill in the needed words:

いつかあの _____ に _____ ことがあると思います。

Itsu ka ano _____ ni _____ koto ga aru to omoimasu.

Answers:

1. a (The use of a respectful, i.e. depreciatory verb indicated that the other person is in some way connected with the film.)
2. 方 **kata** and お会いした **o-ai shita**
3. 人 **hito**; 会った **atta**

In all the examples we have had of depreciatory verbs showing respect to a 3rd person, polite **masu**-level endings were used. Remember, though, that as in the case of the honorifics (or any other verbs), these endings express respect *not* to the 3rd person, but to the second person only.

For example, in

出来るだけ早く大使にご連絡するつもりです

Dekiru dake hayaku taishi ni go-renraku suru tsumori desu,

respect for the ambassador is shown by the use of the words ご連絡 **go-renraku**,

and for the person addressed by the use of です **desu**.

If, therefore, the person addressed does *not* need to be shown respect, **masu**⁺ can be omitted without in any way weakening the respect shown to the 3rd person.

Thus, if the above sentence were addressed to a familiar or “inferior”, it could well end with a plain form instead:

出来るだけ早く大使にご連絡するつもりだ。

Dekiru dake hayaku taishi ni go-renraku suru tsumori da.

On the other hand, **masu**⁺ is always needed with a depreciatory verb when it is the 2nd person who is involved and respect is being shown to him.

Hence the standard polite phrase “I’m pleased to meet you”, that is

はじめてお目にかかります。

Hajimete o-me ni kakarimasu.

“I meet you for the first time.”

Similarly,

どちらでお目にかかりましょう。

Dochira de o-me ni kakarimashō.

“Where shall I meet you?”

窓をお開けしましょうか。

Mado o o-ake shimashō ka.

“Shall I open the window [for you]?”

これをお借り/拝借してもいいですか。

Kore o o-kari/haishaku shite mo ii desu ka.

“May I borrow this [from you]?”

お読み/拝見しました。

O-yomi/Haiken shimashita.

“I read it [for/thanks to you].”

Remember, though, that it is just as necessary for the 2nd person to be involved in the action before a depreciatory verb can be used as it is in the case of a 3rd person.

Hence,

“I have bought it [for/from/thanks to etc. you]” can be

お買いしました

O-kai shimashita

or

お買いいたしました

O-kai itashimashita;

but “I have bought it”, expressed simply as a piece of information not directly connected with the other person, would be simply

買いました。

Kaimashita.

どこまでお話しましたかね

Doko made o-hanashi shimashita ka ne

therefore means

“How far did I get, then, in what I was saying [to you]?”

To sum up, then, depreciatory verbs (and honorific verbs too, apart from the exceptional “plain honorifics” used to and of a 2nd person—see pages 69–70) can be used:

- A. in their plain forms (i.e. without **ます masu**⁺) to show respect to the 3rd person and no respect to the 2nd; and
- B. in their polite forms (i.e. with **ます masu**⁺) to show respect either
 - (i) to the 3rd person by means of the depreciatory verb, and to the 2nd person by means of the **ます masu**⁺; or
 - (ii) to the 2nd person only by means of both the depreciatory verb and the **ます masu**⁺.

Practice

1. To whom, then, could いただきました **Itadakimashita** “I (humbly) received” show respect? (Be careful!)
 - a. To both the 2nd and 3rd persons
 - b. To the 3rd person only
 - c. To the 2nd person only

2. To whom could いただいた **Itadaita** “I (humbly) received” show respect?
 - a. To the 2nd person only
 - b. To the 3rd person only
 - c. To neither person

3. お目にかかりました **O-me ni kakarimashita** can express respect only to the 2nd person and can only mean “I (humbly) met you”. True or false?

Answers:

1. a or c
2. b
3. Answer: F (It can also mean “I (humbly) met him”—see B(i) above.

CHAPTER 6

Depreciatory Verbs: (b) Permissive Constructions

Some expressions widely used in respect language make special use of the verb もらう **morau**⁺ “receive (from a superior)” and its depreciatory equivalent いただく **itadaku**⁺.

These two words are basically ordinary transitive verbs, もらう **morau**⁺ commonly being used when extreme respect is not felt to be necessary, and いただく **itadaku**⁺ when it is.

Thus, although

これを/がもらいたいです **Kore o/ga moraitai desu** can mean either

- a. “I would like to have this (from *you*)”, or
- b. “I would like to have this (from *him*)”,

which will it more often mean, since もらう **morau**⁺ is the less respectful of the two verbs? That’s right: it would usually mean the second option, b. (Notice that を **o** and が **ga** are given as alternatives because either can now be used after the “object” of a verb in the たい **tai** form.)

Sentence a., then, would more often be, in Japanese,

これを/がいただきたいです。

Kore o/ga itadakitai desu.

In the following examples, therefore, let's assume that もらう **morau**⁺ shows respect to the 3rd person, and いただく **itadaku**⁺ to the 2nd.

When these verbs are used as ordinary transitive verbs, the "giver" (if mentioned) is followed by から **kara** "from". For example:

"My brother received this from my father."
 (わたしの)兄は父からこれをもらいました。
(Watashi no) ani wa chichi kara kore o moraimashita.

Verbal nouns (in the form **o** + verb base) can also be used with もらう **morau**⁺ and いただく **itadaku**⁺; but in this case the accusative particle **o** is not needed:

ちょっとお待ちいただけますか。
Chotto o-machi itadakemasu ka.

"Can I receive your waiting for just a moment?", that is
 "Can (I have) you wait (note the use of the potential いただけます **itadakemasu**) for just a moment?"

A causative verb can also be used in this way:

ご旅行のお話をお聞かせいただけませんか。
Go-ryokō no o-hanashi o o-kikase itadekenai deshō ka.

"Don't you think I could receive an allowing-to-hear you talk about your trip?", that is
 "Can't I get you to tell me/Can't I hear about your trip?"

In an extension of this ordinary transitive use, もらう **morau**⁺ and いただく **itadaku**⁺ can follow the て **te** form of a verb when the ordinary use of the causative form of that verb degrades too much the person "made" to go etc.:

早く帰ってもらいました。

Hayaku kaette moraimashita.

"I had a going-home-early [by him]", that is

"I had him/I got him to go home early."

(An ordinary causative [早く帰らせました **Hayaku kaeremashita** "I let him go/sent him home early"] would mean that the 3rd person was in the position of having to do what the speaker wished.)

早くいらっしやっていただきたいです。

Hayaku irasshate itadakitai desu.

"I want to have you/I would like you to come early."

In this construction with the **te** form of another verb, the other person who performs the action of the て **te** verb, if mentioned, is followed by に **ni**:

(a) 私はあの人に行ってもらいたいです。

Watashi wa ano hito ni itte moritai desu.

(b) "I want to receive a going *by* him", that is

(c) "I want him to go."

Similarly,

(a) 友達はその問題を先生に説明してもらいたいと言っています。

Tomodachi wa sono mondai o sensei ni setsumei shite moritai to itte imasu.

(b) "My friend says that he wants to receive an explaining of that problem by the teacher", that is

(c) "My friend says he wants the teacher to explain that problem."

Practice

Try these examples, working in the opposite direction; that is, beginning with the English.

1. (c) "I want you/would like you to open that window for me."
 (b) "I want to receive an opening of that window by you."
 (a) 私は(あなた _____) その窓を開けて _____ です。
Watashi wa (anata _____) sono mado o akete _____ desu.

2. (c) "My mother says that she would like you to buy a few things for her."
 (b) "My mother says that she would like to receive the buying of a few things by you."
 (a) 母は(あなた _____) ちょっと買い物をして _____ なのですが。
Haha wa (anata _____) chotto kaimono o shite _____ sō desu ga.

3. (c) "I didn't want him to go home."
 (a) あのひと _____ 帰って _____ ありませんでした。
Ano hito _____ kaette _____ arimasen deshita.

4. (c) "I got him to make a box for me."
 (a) _____ 箱を作って _____ 。
 _____ **hako o tsukutte _____ .**

The verbs **morau**⁺ and **itadaku**⁺ are also used to express an implied imperative:

5. (c) "I'll have you go for me, then."
 (a) じゃあ、行って _____ ます。
Jyā, itte _____ masu.

6. (c) "Let's get him to look for it (for us)."
 (a) (あの人に) さがして _____ しましょう。
(Ano hito ni) sagashite _____ mashō.

Answers:

1. に **ni**; いただきたい **itadakitai**
2. に **ni**; いただきたい **itadakitai**
3. に **ni**; もらいたく **moraitaku**
4. あのひと **Ano hito ni**; もらいました **moraimashita**
5. いただき **itadaki**
6. もらい **morai**

Sometimes the て **te** form before もらう/いただく **morau/itadaku**⁺ is that of a causative (or, more accurately here, a *permissive*) verb:

友達に行かせてもらいました。

Tomodachi wa ikasete moraimashita.

“My friend received an allowing-to-go”,
that is

“My friend was allowed to go.”

Similarly,

私も失礼させていただきます。

Watashi mo shitsurei sasete itadakimasu.

“I too will receive [from you] an allowing-to-be rude (i.e. to leave)”,
that is

“I’ll leave too (if you don’t mind).”

“I was allowed to go by car.”

“I received an allowing-to-go by car.”

私は車で行かせてもらいました。

Watashi wa kuruma de ikasete moraimashita.

“That student is allowed to study in the teacher’s room every day.”

あの学生は毎日先生の部屋で勉強させてもらいます。

Ano gakusei wa mainichi sensei no heya de benkyō sasete moraimasu.

Usually the person who does the “allowing” is clear from the context (in the example above, for example, it is presumably the teacher); but if he is to be explicitly stated, に **ni** is used with him (as the “subject” of the permissive て **te** form verb) just

as it is in the ordinary てもうら/いただく **te morau/itadaku** construction.

In other words, whoever does the action of the て **te** form verb (the “doing” or the “allowing”) can be followed by に **ni**.

Thus, in the ordinary てもらう/いただく **te morau/itadaku** construction, we have

“I got my father to go.”

“I received a going by my father.”

私は父に行ってもらいました。

Watashi wa chichi ni itte moraimashita.

And in the permissive せてもらう/いただく **sete morau/itadaku** construction, we have

“I got my father to let me go.”

“I received an *allowing-to-go* by my father.”

私は父に行かせてもらいました。

Watashi wa chichi ni ikasete moraimashita.

“I got my friend to let me use his car.”

私は友達に車を使わせてもらいました。

Watashi wa tomodachi ni kuruma o tsukawasete moraimashita.

In such permissive sentences, the person governed by に **ni** is normally taken to be the one who “allows” rather than “goes/uses” etc.:

(a1) 私は父に行かせてもらいました。

Watashi wa chichi ni ikasete moraimashita.

(a2) “I received an *allowing-to-go* by my father.”

(a3) “I got my father to let me go.”

But another meaning is possible, though less usual. Given a situation in which one person has asked another to allow or make a 3rd person do something, it is possible for such sentences to mean

- (b1) 私は父に行かせてもらいました。
Watashi wa chichi ni ikasete moraimashita.
- (b2) "I received (from someone) an allowing *to-go-by-my-father*."
 (b3) "I got (someone) to let my father go."

There can be much the same ambiguity, therefore, in
 私は父に行かせてもらいました

Watashi wa chichi ni ikasete moraimashita

as in the English sentence

"I received permission for a visit from my father".

But, in Japanese, the person who "allows" can easily be distinguished if necessary, by using a phrase like 父に頼んで **chichi ni tanonde** "by requesting."

Hence, (a3) above, "I got my father to let me go," could become

"I received an allowing-to-go by requesting my father."

私は父に頼んで行かせてもらいました。

Watashi wa chichi ni tanonde ikasete moraimashita.

If it is a third person who can be said to be allowed or made to do something, he can also be mentioned by using に **ni** with him, as in the (b) sentences above:

"I got my teacher to let my friend go too."

"I received an allowing-my-friend-to-go-too by requesting my teacher."

私は先生に頼んで友達にも行かせてもらいました。

Watashi wa sensei ni tanonde tomodachi ni mo ikasete moraimashita.

It is seldom necessary to be so explicit, however, and the main thing to remember is that the person who allows someone to do something in a せてもらういただく **sete morau/itadaku** construction can be indicated by に **ni** or, if necessary, by いたのんで **ni tanonde**; that is, by に (たのんで) **ni (tanonde)**:

"I will get my friend to let me use his car."

"I will receive an allowing-to-use his car by (requesting) my friend."

私は友達に(頼んで)車を使わせてもらいます。

Watashi wa tomodachi ni (tanonde) kuruma o tsukawasete moraimasu. (cf. page 103)

Briefly, then, in てもらういただく **te morau/itadaku** constructions the "subject" of the て **te** form verb is not often stated; but if it is stated, it is followed by に **ni** in the ordinary construction, and by に (頼んで) **ni (tanonde)** in the permissive せてもらう/いただく **sete morau/itadaku** construction.

Practice

1. "I got him to read the book (for me)."

私はあの _____ もらいました。

Watashi wa ano _____ moraimashita.

2. "I got him to let me read the book."

私はあの _____ もらいました。

Watashi wa ano _____ moraimashita.

Answers:

- 人に本を読んで **hito ni hon o yonde**
- 人に(頼んで)本を読ませて **hito ni (tanonde) hon o yomasete**

Such permissive constructions are very common in Japanese. Often, when direct expressions like "I want to go", "I would like to go", and "May I go?" are acceptable in English, the Japanese prefer to use permissive **せてもらう/いただく** **sete morau/itadaku** constructions equivalent to "I would like to be allowed to go" etc.

For example,

"I would like to read that book of yours."

"I would like to be allowed to read that book of yours."

その本を読ませていただきたいです。

Sono hon o yomasete itadakitai desu.

Practice

1. "Could I (be allowed) go with you?"

お供させて _____ るでしょうか。

O-tomo sasete _____ ru deshō ka.

2. "Don't you think I could (be allowed to) go with you?"

_____ ないでしょうか。

_____ **nai deshō ka.**

3. "I listened to my friend's radio," that is,
-
- "I had my friend
- let me listen*
- to his radio."

私は友達のラジオを _____ もらいました。

Watashi wa tomodachi no rajio o _____ moraimashita.

4. "I'll just (get you to allow me to) stay here with you for a while."

ちょっとおじゃま _____ ます。

Chotto o-jama _____ masu.

5. "I couldn't (get him to let me) use his car."

(あの人に頼みましたが) 自動車を使わせて _____
ませんでした。

**(Ano hito ni tanomimashita ga) jidōsha o tsukawasete
_____ masen deshita.**

Answers:

1. いただけ **itadeke**
2. お供させていただいだけ **O-tomo sasete itadake**
3. 聞かせて **kikasete**
4. させていただきます **sasete itadakimasu**
5. もらえ **morae**

いただく **Itadaku**⁺, in particular, is much used after the causative/missive forms of depreciatory verbs in the most typical expressions of this kind:

“I’ll just (get you to let me) have a look.”
ちよつと拝見させていただきます。

Chotto haiken sasete itadakimasu.

This is clearly an alternative for a straightforward imperative consisting of, for example, the same depreciatory verb and **kudasai**:

“Please let me see it for a moment.”
ちよつと拝見させてください。

Chotto haiken sasete kudasai.

In fact, shortened forms without any true final verb at all are frequently used instead of the full sentences ending in いただきます **itakakimasu**, ください **kudasai** and equivalent words:

ちよつと拝見させて **Chotto haiken sasete**, or simply
ちよつと拝見 **Chotto haiken**.

One of the most common endings in such abbreviated expressions is ちょうだい **chōdai** which, in its full form ちょうだいする/いたす **chōdai suru/itasu**⁺, stands with いただく **itadaku**⁺ as a depreciatory for もらう **morau**⁺ “receive”, たべる **taberu**⁺ “eat” and 飲む **nomu**⁺ “drink”.

When used alone, ちょうだい **chōdai** is a contraction of some such permissive construction as ちょうだいさせていただきます **chōdai sasete itadakimasu** “I will have you allow me to receive”. But for practical purposes it can be regarded as an alternative for ください **kudasai** for, like that word, it is used both with a direct object:

お塩ちょうだい

O-shio chōdai

“I would like to have (ちょうだい **chōdai**) the salt”;

and with the **te** form of another verb:

歌を歌ってちょうだい

Uta o utatte chōdai

“I would like to have you sing a song”.

One final point: since a speaker is likely to be more respectful to a person he is addressing directly than to someone he is mentioning but who may not even be present (see the situation diagrams in Appendix 1), the above examples used the more respectful いただく **itadaku**⁺ to show respect to the 2nd person and the less respectful もらう **morau**⁺ to show respect to the 3rd person.

This reasonably represents average usage, but it is, of course, only a general guide and not a hard and fast distinction.

When talking informally to a friend, for example, some men will regularly say for

“Can I have this from you, do you think?” *not*

これを/がいただけるでしょうか

Kore o/ga itadakeru⁺ **deshō ka**

but instead,

これを/がもらえるでしょうか。

Kore o/ga moraeru deshō ka.

*. Note with a potential verb, が **ga** is strictly more correct, but を **o** is also common.

Conversely, it is not uncommon to hear a woman say
 “I suppose I can’t have that [from him]?”
 それを/がいただけないでしょうね。
Sore o/ga itadakenai deshō ne.

Practice

Now, using an appropriate form of もらう **morau**⁺ or いただく **itadaku**⁺ and observing the convention of showing respect to a 2nd person by the use of いただく **itadaku**⁺ and to a 3rd person by the use of もらう **morau**⁺, translate the following sentences into Japanese.

1. “My brother received this from you.”

兄はこれを _____。

Ani wa kore o _____.

2. “I had this from my friend.”

(わたしは) _____ 友達から _____。

(Watashi wa) _____ tomadachi kara _____.

3. “He had his friend go.”

(あの人は) 友達 _____。

(Ano hito wa) tomodachi _____.

4. “I would like to have you look at it.”

(あなた _____) ご覧に _____。

(Anata _____) goran ni _____.

5. “I’ll get you to visit him, then.”

じゃあ、あの人を _____。

Jyā, ano hito o _____.

6. “Let’s get him to bring it.”

あの人 _____。

Ano hito _____.

7. “I got my father to let me wait.”

私は _____ 頼んで _____。

Watashi wa _____ tanonde _____.

8. “I couldn’t get my father to let me wait.”

私は _____ 頼みましたが _____
 でした。

**Watashi wa _____ tanomimashita ga _____
 _____ deshita.**

Answers:

1. あなたからいただきました **anata kara itadakimashita** (If you got this wrong, refer back to pages 97–98.)
2. これを **kore o**; もらいました **moraimashita**, or (私は) 友達からこれをもりました (**Watashi wa**) **tomodachi kara kore o moraimashita** (If you got this wrong, refer back to pages 97–98.)
3. に行ってもらいました **ni itte moraimashita** (If you got this wrong, refer back to pages 98–100.)
4. に (**ni**); なっていただきたいです **natte itadakitai desu** (If you got this wrong, refer back to pages 98–100.)
5. 訪ねていただきます **tazunete itadakimasu** (If you got this wrong, refer back to page 101.)
6. に持ってきてもらいましょう **ni motte kite moraimashō** (If you got this wrong, refer back to page 101.)
7. 父に **chichi ni**; 待たせてもらいました **matasete moraimashita**
8. 父に **chichi ni**; 待たせてもらえません **matasete moraemasen** (If you got this wrong, refer back to pages 103–105 and page 107, #5.)

Finally—and more for light relief than anything else, since you are given no context to help—try to work out the meaning of the following sentence. Read down stage by stage, until you see the meaning, and understand how the translation is reached.

1. 手紙を書いてもらってやってください。
Tegami o kaite moratte yatte kudasai.
2. 手紙を書いてもらってやって。
Tegami o kaite moratte yatte, please (=ください kudasai).

やる **Yaru**+ “give” being the neutral equivalent of the depreciatory あげる **ageru**+ “give” [to a superior]” (see page 78, (て) やる (-te) **Yaru**+ means “(do) for [an equal or inferior]”.

3. 手紙を書いてもらって
Tegami o kaite moratte for him (= やって **yatte**), please.

書いてもらう **Kaite morau**+ means “receive the writing [from a superior]”.

4. 手紙を書いてもらってやってください。
Tegami o kaite moratte yatte kudasai.
“Receive the writing of a letter for him, please.”

Or “Please have/get a letter written for him.”

Now, let’s take a closer look. Does the use of やる **Yaru**+ indicate that the 2nd person is at least equal, and probably senior, to the person for whom the letter is requested? Yes. (Because if he were clearly junior, あげる **ageru**+ would have been used instead; see #2’s note.)

Note also that the use of (書いて) もらう (**kaite**) **morau**+ indicates that the 2nd person is junior to the person from whom the letter is required. (If he were senior, only the ordinary causative 書かせる **kakaseru**+ “cause to write/make write” would be needed; see pages 98–99.)

CHAPTER 7

Deferential Verbs

We saw that respect can be shown to the 2nd person by using depreciatory verbs together with **ます masu⁺** endings.

We also mentioned that there is a handful of depreciatory verbs which are generally felt to be so respectful that they are normally used *only* for this purpose and virtually never to show respect to the 3rd person.

Since, like **ます masu⁺**, these verbs express *deference* from the speaker to the person he is addressing, let's distinguish them from ordinary depreciatory verbs by calling them deferential verbs.

Depreciatory verbs can show respect to either the 2nd or 3rd persons; deferential verbs show respect only to the 2nd person.

Two deferential verbs are best treated as isolated cases:

- (a) **しております de orimasu⁺** for **だ da⁺** (with animate subjects only):

“That is my intention” can take the form

“I am (here) with that intention.”

私はそのつもりしております。

Watashi wa sono tsumori de orimasu.

This verb is a deferential equivalent to the honorific **でいらっしゃる de irassharu⁺**, but it is not very much used, a simple **です desu⁺** or **でございます de gozaimasu⁺** (mentioned below) usually being preferred.

(b) **存じます zonzjimasu⁺** for **知る shiru⁺** and **思う omou⁺**:

“You probably know, but I don’t.”

あなたをご存知でしょうが、私は存じません。

Anata wa go-zonji deshō ga, watashi wa zonzjimasen.

次の問題に移りたいと存じます。

Tsugi no mondai ni utsuritai to zonzjimasu.

“I would like to pass on to the next question.”

But the most important deferential verbs fall into three bigger groups which may be summarized as the use of:

(i) **申します/申し上げます mōshimasu⁺/mōshiagemasu⁺** for **する/いたす suru⁺/itasu⁺** in verb forms having **する/いたす suru⁺/itasu⁺** as part of the depreciatory:

お願いする/いたす お願い申します/申し上げます。

O-negai suru⁺/itasu⁺ → O-negai mōshimasu⁺/mōshiagemasu⁺.

“I (humbly) request you.”

山田先生をご紹介申し上げます。

Yamada sensei o go-shōkai mōshiagemasu.

“I shall/Let me introduce Professor Yamada to you.”

and, using a plain form of the verb before a noun,
ご連絡申し上げるつもりでございました。

Go-renraku mōshiageru tsumori de orimashita.

“I intended to contact you.”

(ii) **いたします itashimasu⁺** for **する suru⁺** in the **勉強する benkyō suru** type of verb which, because no other person is involved, uses only **する suru⁺** at the depreciatory level:

“I would like to contact you.”

ご連絡いたします。

Go-renraku itashimasu.

“I traveled all over Europe.”

ヨーロッパ中を旅行いたしました。

Yōroppa-jū o ryokō itashimashita.

(iii) **おります orimasu⁺** for **いる iru⁺** “be (present)”
参ります mairimasu⁺ for **参る mairu⁺** “come, go”
ございます gozaimasu⁺ for **ある aru⁺** “be, exist”
and
でございます de gozaimasu⁺ for **だ da⁺** “be”

A unique characteristic of the verbs of this last group is that, in showing respect to the person addressed through both the verb itself and **ます masu⁺**, they can be used with any appropriate subject, including impersonal ones. (The person addressed, his associates, or generally exalted persons would naturally be inappropriate as subjects of such deferential verbs.)

Practice

Translate, or supply deferential verbs for, the following sentences.

1. 弟は _____。

Otōto wa _____.

“My brother is not here.”

2. エアコンもついて _____。

Eakon mo tsuite _____.

“Air-conditioning is installed too.”

3. “I’ve not heard a single word.”

ひとつことも伺っては _____。

Hitokoto mo ukagatte wa _____.

4. お待ちして _____。

O-machi shite _____.

“I was waiting for you”, that is

“I was looking forward to you coming.”

5. では、明日六時にお待ち申して _____。

De wa, ashita rokuji ni o-machi mōshite _____.

“I’ll be expecting you/looking forward to you coming at six tomorrow, then.”

6. “I’ll come immediately.”

私はすぐ _____。

Watashi wa sugu _____.

7. ぜひ一度お目にかかりたいと存じて _____。

Zehi ichido o-me ni kakaritai to zonjite _____.

“(I felt) I certainly wanted to meet you on some occasion.”

8. “I know your name well.”

お名前はよく存じて _____。

O-namae wa yoku zonjiagete.

(Remember that, unlike 存じます **zonjimasu**⁺, 存じる **zonjiageru**⁺ is a depreciatory, i.e. it can be used to show respect to either the 2nd or 3rd person— see page 78.)

9. 庭の花が香って _____。

Niwa no hana ga kaotte _____ (香る **kaou vi.** “smell”)

“The garden flowers bring/put/give out their scent.”

10. “It’s suddenly turned cold, hasn’t it?”

急に寒くなって _____ ね。

Kyū ni samuku natte m _____ **ta ne.**

11. “There is no table here.”

ここにはテーブルが _____。

Koko ni wa tēburu ga g _____.

12. "Do you have any brother or sister?"

(あなたには) ごきょうだい が _____。

(Anata ni wa) go-kyōdai ga _____ ka.

13. "No, I don't."

いいえ、(私には) _____。

Iie, (watashi ni wa) _____.

14. "This is a very rare book."

これは大変めずらしい本で _____。

Kore wa taihen mezurashii hon de _____.

15. "There is a telephone beside the bed."

枕元に電話が _____。

Makuramoto ni denwa ga _____.

16. "I am a student."

私は学生 _____。

Watakushi wa gakusei _____.

17. "Was this your car?"

これはあなたの自動車 _____。

Kore wa anata no jidōsha _____ ka.

Answers:

1. おりません orimasen
2. おります orimasu
3. おりません orimasen
4. ありました orimashita
5. おります orimasu
6. 参ります mairimasu
7. ありました orimashita
8. おります orimasu
9. 参ります mairimasu
10. 参りました mairimashita

If #9 and #10 above were at the ordinary neutral level of politeness, 参ります **mairimasu** and 参りました **mairimashita** would be 来ます **kimasu** and 来ました **kimashita** respectively.

11. ございません gozaimasen
12. ございます gozaimasu
13. ございません gozaimasen (or おりません orimasen)
14. ございます gozaimasu
15. ございます gozaimasu
16. でございます de gozaimasu
17. ございました de gozaimashita

The above examples illustrate the general uses of おります **orimasu**⁺, 参ります **mairimasu**⁺, and でございます **(de) gozaimasu**⁺, but three points should be mentioned about 参ります **mairimasu**⁺ and でございます **(de) gozaimasu**⁺.

- (a) 参ります **mairimasu**⁺ can either show respect to a 3rd person (because of the use of the verb 参る **mairu**⁺) and, at the same time, to the 2nd person also (because of the use of ます **masu**⁺); or both verb and ending can be used to show respect to the 2nd person only.

It is only in the latter case that it is a true deferential, like the other verbs in this group.

It is only when 参ります **mairimasu**⁺ is used as a true deferential that it can have an impersonal subject.

Thus, in a sentence like

先生を待っておりましたが、遅くなって参りました。

Sensei o matte orimashita ga, osoku natte mairimashita.

“I was waiting for the teacher, but it grew late”, 参りました **mairimashita** (like おりました **orimashita**) is used to show respect to the 2nd person/person addressed, and not to the 3rd person/teacher.

(b) ございます **gozaimasu**⁺ and でございます **de gozaimasu**⁺ are not found in their plain forms. Before nouns and in subordinate clauses etc., where the plain forms of verbs are normally used (e.g. 東京にある建物 **Tōkyō ni aru tatemono**), they sometimes remain as (で) ございます (**de**) **gozaimasu**⁺:

“It’s inside the box.”

箱の中にございます。

Hako no naka ni gozaimasu.

“Since he is a student”

学生でございますので

Gakusei de gozaimasu no de

More frequently, however, they are replaced by words used at a lower level of respect, without affecting the general ございます **gozaimasu** level. These words are ある **aru**⁺ and the particle の **no**, for ございます **gozaimasu**⁺; and, for でございます **de gozaimasu**⁺, である **de aru**⁺ (in written or very formal spoken

styles), its more colloquial equivalent だ **da**⁺, the な **na** which replaces だ **da** in certain expressions, and the particle の **no**.

You will have met all these words at the ordinary neutral level of respect, but at the respectful level too the meanings of (で) ございます (**de**) **gozaimasu**⁺ are covered by (で) ある (**de**) **aru**⁺ in:

“Since it’s inside the box”

箱の中にある/ありますので

Hako no naka ni aru/arimasu no de

“Although he/was a student”

学生であった/ありました/ございましたのに

Gakusei de atta/arimashita/gozaimashita no ni

“I think he is a student.”

学生であると存じます。

Gakusei de aru to zonjimasu.

“The fact that they were imported goods”

輸入品であった/ありましたこと

Yunyūhin de atta/arimashita koto

And they are covered by だ **da**⁺ in:

“I think she is pretty.”

きれいだと存じます。

Kirei da to zonjimasu.

and

“I think it will (probably) be a university student.”

大学生だろうと存じます。

Daigakusei darō to zonjimasu.

And they are covered by な **na** in:

“Although she is pretty”

きれいなのに

Kirei na no ni

and

“Since he is a student”

学生なので

Gakusei na no de

or by の **no** in:

“Things in the box”

箱の中の物

Hako no naka no mono

(c) ございます **gozaimasu**⁺ and でございます **de gozaimasu**⁺ will be found widely used by some people as general respect forms, even with subjects closely associated with the person addressed. For example, many people say for

“Do you have any children?”

お子さんがございますか

O-ko-san ga gozaimasu ka

instead of using the *honorific* equivalent of ございます **gozaimasu**:

お子さんがおありになりますか。

O-ko-san ga o-ari ni narimasu ka.

When such a subject is *a person* connected with someone who is being addressed and not with the speaker, he should be shown the same respect as if he were being addressed directly (see the

standard situation on pages 23–24 or Appendix 1E).

If respect is shown, then, it should be in the form of an honorific verb.

Of the two possible translations for “Do you have any children?” above, therefore, the more correct is

お子さんがおありになりますか。

O-ko-san ga o-ari ni narimasu ka.

Similarly, でございます **de gozaimasu**⁺ is often used with such subjects, in place of the honorific equivalent for だ **da**⁺, which is でいらっしゃる **de irassharu**⁺ (or でおいでになる **de oide ni naru**⁺) with animate subjects.

Both でございます **de gozaimasu**⁺ and でいらっしゃる **de irassharu**⁺ are widely used in such sentences, but, from what has been said above about ございます **gozaimasu**⁺, which do you think is the more correct translation for “Is this your child?” It is

こちらは(あなたの)お子さんでいらっしゃいますか。

Kochira wa (anata no) o-ko-san de irasshaimasu ka.

When the subjects are *inanimate* but still connected only with the person addressed, it is likewise held to be more correct, strictly speaking, to use the honorific forms (で)おありになる (**de**) **o-ari ni naru**⁺, as on page 60, #2:

“Hasn’t your elder brother had that kind of experience?”

お兄さんにはそういう経験がおありになりませんか。

O-nii-san ni wa sō yū keiken ga o-ari ni narimasen ka.

and page 60, #3:

お宅は旧家でおありになりますね。

O-taku wa kyūka de o-ari ni narimasu ne.

“Yours is an old family, isn’t it?”

But, since there can usually be no objection to depreciating the status of something which is inanimate, the use of (で) ございます (de) **gozaimasu**⁺ in such cases is much more common than the use of honorific equivalents.

Thus, the last two Japanese sentences above would more often be

お兄さんには そういう経験がございませんか

O-niisan ni wa sō yū keiken ga gozaimasen ka

and お宅は旧家でございますね。

O-taku wa kyūka de gozaimasu ne. (cf. page 120, #17)

Now that we have available to us both *honorifics* (which show respect to their subject) and *depreciatories* (which lower the status of their subject to show respect to someone else who is involved), we can consider an interesting situation which the Japanese can only overcome by a *combination of the two*.

This situation occurs when someone is talking *to* a person to whom he wishes to show respect *about* the actions of a 3rd person to whom he also wishes to be respectful.

He has two choices: the simpler is to use an honorific verb to show respect to the 3rd person (its subject) and a **ます masu** ending to show respect to the person he is addressing:

“The teacher was in America for a long while.”

先生は長い間アメリカにいらっしゃいました。

Sensei wa nagai aida Amerika ni irasshaimashita.

But the 2nd person does not do very well out of this: he is offered only a polite **ます masu** ending, and this seems insignificant beside the full honorific provided for a 3rd person who may not even be present.

Very often, therefore—especially if the 3rd person is not within hearing—the 2nd person is first gratified by the use of a depreciatory or deferential verb (with the 3rd person as its subject), as well as by a **ます masu** ending:

先生は長い間アメリカにおりました。

Sensei wa nagai aida Amerika ni orimashita.

The now inferior status of the 3rd person is then rectified somewhat by giving the depreciatory or deferential verb an honorific passive ending:

先生は長い間アメリカにおられました。

Sensei wa nagai aida Amerika ni oraremashita.

Such a combination of forms is often the only way out of a social dilemma.

For example, if an office clerk were to say to a visitor about another clerk “He isn’t here at the moment, sir” he would not need to use anything more than an ordinary deferential:

今ちょっとおりません。

Ima chotto orimasen.

But if he were to tell the visitor that the manager was not there, he might feel the need to soften the status-lowering effect of the verb on its subject (in this case “the manager”) by using the honorific passive form of **おる oru**⁺:

今ちょっとおられません。

Ima chotto oraremasen.

Similarly, ordinary depreciatories and deferentials would be used in such sentences as:

“My brother says that he would like to see you, sir”

私の弟はお会いしたいと申しております

Watakushi no otōto wa o-ai shitai to mōshite orimasu

but would perhaps be modified in:

“The foreign gentleman there says he would like to see you, sir.”

あの外国人の方はお会いしたいと申されています。

Ano gaikokujin no kata wa o-ai shitai to mōsarete imasu.

Now consider the following sentences and their use of 参った **maitta** or 参られた **mairareta**.

“I believe my teacher went to see the university president.”

先生は大学総長のところへ参られたそうです。

Sensei wa daigaku sōchō no tokoro e mairareta sō desu.

(Note that the same method can be used when, as here, the competition for respect is between two 3rd persons, in this case the teacher and the president.)

“I believe my elder sister went to see the university president.”

私の姉は大学総長のところへ参ったそうです。

Watashi no ane wa daigaku sōchō no tokoro e maitta sō desu.

Although, in theory, this honorific passive form is usable with a number of depreciatory and deferential verbs, in practice it is most often found with おる **oru**⁺, 申す **mōsu**⁺ and 参る **mairu**⁺.

CHAPTER 8

Imperative Forms

The true imperatives peculiar to respect language are comparatively simple, and are on two levels of politeness.

The lower level has affirmative forms consisting of the plain imperatives of the honorifics:

でいらっしやい de irasshai	“be!” (with animate subjects only)
いらっしやい irasshai	“be!/go!/come!”
おっしやい osshai	“say!”
なさい nasai	“do!” (e.g. お読みなさい o-yomi nasai)
ください kudasai	“condescend! → do!/please...!” (e.g. 読んで/お読みください yonde/o-yom kudasai)
召し上がれ meshiagare	“eat!/drink!”

Thus, since the plain imperatives of the honorifics 召す **mesu**, 思し召す **oboshimesu** and 上がる **agaru** are not used, 召し上がれ **meshiagare** is the only honorific imperative at this level which does not end in あい **ai**.

Hence,

“Come quickly!”

早くいらっしやい。

Hayaku irasshai.

Practice

1. "Study as hard as you can!"

一所懸命にご勉強 _____。

Issho kenmei ni go-benkyō n _____.

2. "Please talk things over at any time."

いつでもご相談 _____。

Itsu de mo go-sōdan k _____.

3. "Wait a moment!"

ちょっとお待ち _____。

Chotto o-machi n _____.

4. "Please wait a moment."

ちょっと待って/お待ち _____。

Chotto matte/o-machi k _____.

5. "Do (please) eat a lot!"

(どうぞ)たくさん _____。

(Dōzo) takusan m _____.

Answers:

1. なさい **nasai**
2. ください **kudasai**
3. なさい **nasai**
4. ください **kudasai**
5. 召し上がれ **meshiagare**

Unlike the other imperatives at this level, however, 召し上がれ **meshiagare** is normally used only to children or intimate friends.

The most common imperative use of 召し上がる **meshiagaru** is in its **te** form with ください **kudasai**:

"Do please eat a lot!"

(どうぞ)たくさん召し上がってください。

(Dōzo) takusan meshiagatte kudasai.

The てください **te kudasai** construction is in fact a very common imperative with honorific verbs in general, as it is with neutral verbs.

Thus, "Please say so" can be

そう言ってください

Sō itte kudasai at the neutral level, and

そうおっしゃってください

Sō osshatte kudasai at the honorific;

and "Please do that" can be

そうしてください

Sō shite kudasai or

そうなさって/なすってください

Sō nasatte/nasutte kudasai.

Note in passing the various verbal forms used before くださる **kudasaru**†.

When another honorific verb precedes **くださる kudasaru***, as in the previous examples, that verb must be in the **て te** form.

When a neutral verb (e.g. 行く **iku**, 入る **hairu**, 待つ **matsu**) precedes **くださる kudasaru***, it may be in either the **て te** form or the **を o** + base form (see, e.g., page 132, #4). Hence, "Please go quickly" using honorific verbs is

早くいらっしゃって/いらして/おいでになってください
Hayaku irasshate/irashite/oide ni natte kudasai

but "Please go in" using the neutral verb 入る **hairu*** is
 (どうぞ)入って/お入りください。
(Dōzo) haitte/o-hairi kudasai.

Lastly, verbal nouns which make honorifics with **なさる nasaru*** (e.g. ご連絡 **go-renraku** etc.) can also precede **くださる kudasaru***;

ご返事くださるようお願いいたします。

Go-henji kudasaru yō o-negai itashimasu.

"I ask you to please give me an answer."

The respect level of the **てください te kudasai** construction with honorific verbs lies between the lower and higher levels of the true imperatives of the honorific verbs themselves. Thus,

そうおっしゃい

Sō osshai

is less polite than そうおっしゃってください

Sō osshate kudasai.

The affirmative imperatives at the higher (i.e. more polite) level consist simply of the imperatives of the **ます masu** forms (i.e. **ませ/mashi**) of the verbs used at the lower level:

"(Be so good as to) come this way."

こちらへいらっしゃいませ。

Kochira e irasshaimase (or **いらっしゃいませ irasshaimashi**; such alternatives are assumed below without further mention).

Similarly,

"Kindly drink this"

これをお飲みなさいませ

Kore o o-nomi nasaimase

"Please (condescend to) wait a moment"

ちょっとお待ちくださいませ

Chotto o-machi kudasaimase

and 私のお話を少しお聞きになってくださいましね。

Watakushi no hanashi o sukoshi o-kiki ni natte kudasaimashi ne.

"Please be good enough to listen to a word or two about my story."

Some women still make use on occasion of two very polite imperatives, **あそばせ asobase** and **あそばしませ asobashimase**, in place of **なさい/nasai** and **なさしませ nasai/nasaimase** in any of their uses:

ごめんあそばせ。

Gomen asobase.

"Pardon me."

"Be so good as to treat yourself with great care."

お体をくれぐれもお大事にあそばしませ。

O-karada o kuregure mo o-daiji ni asobashimase.

These imperative forms of the verb **あそばす asobasu** "do" are no longer common, even in women's language. Other forms of this verb are even less used, but may still be met from time to time:

ご主人様は日本で何をあそばしておいでになりますか。

**Go-shujin-sama wa Nippon/Nihon de nani o asobashite
oide ni narimasu ka.**

“What is your husband doing in Japan?”

In ordinary **masu**-level language (i.e. with neutral verbs), this last sentence would be:

ご主人は日本で何をしていますか。

Go-shujin wa Nippon/Nihon de nani o shite imasu ka.

The negative imperatives consist at both levels of the “**な** **negative**” forms of the verbs used in the affirmative imperatives. For example,

“Don’t go”

いらっしゃるな

Irassharu na (lower)

いらっしゃいますな

Irasshaimasu na (higher)

Similarly, “Don’t buy it”

お買いなさるな

O-kai na nasaru na

お買いなさいますな

O-kai na nasaimasu na

and “Don’t study”

ご勉強なさるな

Go-benkyō nasaru na

ご勉強なさいますな

Go-benkyō nasaimasu na.

In practice, however, these direct negative imperatives sound rather blunt, in spite of the honorific forms of the verbs; and they are almost always avoided by using the honorific verbs in such expressions as **ないでください -nai de kudasai** “please don’t”, **てはいけません -te wa ikemasen** “you mustn’t”, **ませんように -masen yō ni** “(I ask you etc.) not to ___” etc.:

“Please don’t go.”

いらっしゃらないでください。

Irassharanai de kudasai.

“You mustn’t do that!”

そうなさってはいけませんよ。

Sō nasatte wa ikemasen yo.

“(I’d like to ask you) not to do that.”

そうなさいませんように。

Sō nasai masen yō ni.

Like the other verb forms used in respect language, the true honorific imperatives at the two levels are listed in Appendix 3.

CHAPTER 9

Adjectives

We have seen how verbs used in modern conversational-style Japanese have plain forms (だ **da**⁺, 行く **iku**⁺, いらっしゃる **irassharu**⁺ etc.) and polite forms (です **desu**⁺, 行きます **ikimasu**⁺, いらっしゃいます **irasshaimasu**⁺ etc.).

Adjectives have corresponding forms, as you doubtless know:

With a “な **na** adjective” like 安全(な) **anzen (na)**, the plain final form is 安全だ **anzen da**,

and the final form showing respect to the person addressed is 安全です **anzen desu**;

and with true Japanese adjectives like 高い **takai**, the plain final form is 高い **takai**,

and the final form showing respect to the person addressed is 高いです **takai desu**.

Adjectives can usually be prefixed by an honorific お **o-** (or ご **go-** in the case of certain な **na** adjectives) provided that the person to whom respect is intended is somehow involved and the word does not already have an initial **o**. For example:

お忙しいところ

O-isogashii tokoro

“When you are so busy”

お若いうちは

O-wakai uchi wa

“While you are young”

今日はお寒いでしょう。

Kyō wa o-samui deshō.

“You (or He/She) must be cold today.”

and お父さんはいかがですか。お元気ですか。

O-tōsan wa ikaga desu ka. O-genki desu ka.

“How is your father? Is he well?”

but お子さんはもう大きくなっていらっしやいますね。

O-ko-san wa mō ōkiku natte irasshaimasu ne.

“Your child has grown big, hasn’t he?”

When the adjective has an initial **o**, it usually takes no prefix (like 大きく **ōkiku** in the example above).

But in the more respectful constructions with **gozaimasu**⁺ and **いらっしやる irassharu**⁺ discussed below, it is possible for 大きい **ōkii**⁺ at least to take the honorific prefix **o** followed by another, old, honorific prefix **mi**.

That is, in very polite language, some forms of 大きい **ōkii**⁺ can be preceded by the compound honorific prefix **おみ omi**.

Although itself now old-fashioned and rare, this compound prefix is still used to make such honorific nouns as **おみ足 omi-ashi** “(your etc.) foot”, **おみくじ omi-kuji** “paper fortune”, and **おみ御付け omi-otsuke**, a common term for (お)みそ汁 (**o**-)misoshiru “miso soup”.

It is also rare, but not unknown, for an ordinary neutral adjective to have a polite or respectful equivalent.

いい/よい **Ii**/**Yoi**⁺ “good”, for example, can be replaced in most of its uses by よろしい **yoroshii**⁺ to give much the same general tone of politeness as when どう **dō** “how?” is replaced by いかか **ikaga**.

When いい/よい **ii**/**yoi**⁺ is used attributively before a noun, よろしい **yoroshii**⁺ can normally only replace it if the noun has just a single syllable. Thus, you will often hear

“Please do whatever suits you”

どうぞ、よろしいようになさってください

Doozo, yoroshii yō ni nasatte kudasai

but “It’s good weather today, isn’t it?”

今日はいいお天気ですね。

Kyō wa ii o-tenki desu ne.

よろしい **Yoroshii**⁺ often replaces いい/よい **ii**/**yoi**⁺ in other uses, however...

“If it is all right/If it suits you”, for example, can be

よければ/よかったら

Yokereba/Yokattara;

but it often becomes instead よろしければ/よろしかったら

Yoroshikereba/Yoroshikattara.

Although few have polite equivalents, adjectives in general do have deferential and honorific forms of their own. (These are listed in Appendix 4 for reference.)

The deferential forms consist, in the case of な **na** adjectives, of the main word followed by **de gozaimasu**⁺ (which is, of course, simply a deferential for **だ da**⁺):

“This table isn’t strong, is it?”

このテーブルは丈夫で(は)ごさいませんね。

Kono tēburu wa jōbu de (wa) gozaimasen ne.

And, in the case of true Japanese adjectives, of **gozaimasu**⁺ preceded by the “long-vowel” form resulting from the elision of the **k** of the adverbial **-く -ku** form. Thus,

高い **takai** → 高く **takaku** → 高う **gozaimasu**
takō gozaimasu “is tall/dear”

Practice

1. 白い **shiroi** → 白く **shiroku** → _____ “is white”
2. おかしい **okashii** → おかしく **okashiku** → _____ “is funny”
3. 大きい **ōkii** → 大きく **ōkiku** → _____ **gozaimasu** “is big”
4. 低い **hikui** → 低く **hikuku** → _____ **gozaimasu** “is low”

Answers:

1. 白う **gozaimasu shirō gozaimasu**
2. おかしゅう **gozaimasu okashū gozaimasu**
3. 大きゅう **ōkyū**
4. 低う **hikū**

Similarly, since the adverbial **く ku** form of いい/よい **ii/yoi** “good” is よく **yoku**,

“It is good” will be
 よう **gozaimasu**.
Yō gozaimasu.

In the case of 多い **ōi** “numerous” (> 多く **ōku**), however, the phonetic discomfort of the theoretical triple vowel is avoided by using the shortened form 多(ごぞいます) **ō (gozaimasu)**.

The honorifics of adjectives consist, in the case of な **na** adjectives, of the main word followed by でいらっしゃる **de irassharu**⁺ (or, rarely, でおいでになる **de oide ni naru**⁺):

お元気でいらっしゃるでしょう。

O-genki de irassharu deshō.

“I suppose you are in good health?”

“You may not like it.”

あなたはお嫌いでいらっしゃるかもしれません。

Anata wa o-kirai de irassharu ka mo shiremasen.

And, in the case of true Japanese adjectives, of the く (て) **ku(te)** form followed by いらっしゃる **irassharu**⁺:

“Your child is big, isn’t he?”

お子様は大きく(て)いらっしゃいますね。

O-ko-sama wa ōkiku(te) irasshaimasu ne.

Such forms are not very common, however; with adjectives, **gozaimasu**⁺ and **de gozaimasu**⁺ are even more widely used to show respect to the person addressed without limitation of subject than they are with nouns. Thus, while such a sentence as

(あなたは)どなた様でございますか

(Anata wa) donata-sama de gozaimasu ka

is still felt by most educated Japanese to be less acceptable than the true honorific form

(あなたは)どなた様でいらっしゃいますか

(Anata wa) donata-sama de irasshaimasu ka,

the strictly correct adjectival honorifics such as 大きく(て) **ōkiku(te) irasshaimasu** are overshadowed by the 大きゅう **ōkyū** (若う **wakō** etc.) **gozaimasu** forms, for these are commonly used even when they refer directly to the person addressed.

Hence,

“Your child is big, isn’t he?”

お子さんは大きゅうございますね。

O-ko-san wa ōkyū gozaimasu ne.

Practice

1. “You are tall, aren’t you?”

あなたは背が _____ ね。

Anata wa se ga _____ ne.

2. “Were there many people in your family?”

お宅の人数は _____ か。

O-taku no ninzū wa _____ ka.

Answers:

1. (お)高うございます (o-)takō gozaimasu
2. 多ございました ō gozaimashita

Practice Readings with Exercises

Practice Readings with Exercises

These texts—three letters and an extract from a play—contain examples of all the main forms of respect language you've learned in Chapters 1 through 9. To help you to consolidate your grasp of these forms, use these texts in the following way:

STEP 1.

First read through the complete text with the aid of a dictionary and the translations provided, which have been made as literal as possible, until you are satisfied you understand all the Japanese.

STEP 2.

Then go through the text again and write down, for each word or part of a word that is numbered and/or given in block capitals, these 3 things:

• **What kind of word it is.** Use these abbreviations:

P = Polite/respectful word (e.g. 私 **watakushi**, ご連絡 **go-renraku**, お分かり **o-wakai**)

H = Honorific verb (respect to subject)

Dp = Depreciatory verb (respect to either 2nd or 3rd person)

Df = Deferential verb (respect to 2nd person only)

- **To whom it shows respect.** Use this simple system:

I = Imperative form

2 = Respect to the 2nd person

3 = Respect to the 3rd person

- **The equivalent form** appropriate to ordinary **ます masu**-level language, i.e. language using mainly neutral verbs and ordinary non-respectful words. (For imperatives, which can have a variety of forms even in **masu**-level language, use (て)ください (-te) **kudasai** as a standard equivalent.)

Examples:

ございました **gozaimashita** could be identified as

Df 2 ありました **arimashita**

いらっしゃい **irasshai** could be identified as

HI 2 来てください **kite kudasai**

Check your identification of the words with the Answer Key. If any of your versions are different, refer back to the pages indicated, to review.

Practice Text 1

Letter from a man, aged 26, to a foreign teacher in his mid-thirties.

拝啓

Haikei,

Respectful greetings,

先日は、素晴らしいお餞別を <1.> _____ ありがとう <2.> _____。祖母をはじめ家内一同ほとほと感服 <3.> _____ ました。

Senjitsu wa subarashii o-senbetsu o <1.> I _____ arigatō <2.> G _____ . Sobo o hajime kanai ichidō hoto-hoto kanpuku <3.> I _____ mashita.

Thank you for the fine farewell gift we received from you the other day. My grandmother and the whole family were most impressed (with it).

全く私どもは日本を知らない日本人とつくづく反省 <4.> _____ ました。

Mattaku Watakushi-domo* wa Nihon o shiranai Nihonji to tsuku-zuku hansei <4.> I _____ mashita.

We reflected very seriously that we are Japanese who do not know Japan.

さて、今度私の叔父高橋次郎もイギリス、ドイツを経てローマへ<5.> _____ ことになりまして、九月二十一日ごろに飛行機で出発<6.> _____。

Sate, kondo watakushi no oji Takahashi Jirō mo Igrisu, Doitsu o hete Rōma e <5.> M _____ koto ni narimashite, kugatsu nijūichi-nichi goro ni hikōki de shuppatsu <6.> I _____ masu.

Well now, it has come about that my uncle Jirō Takahashi is now also going (abroad) to Rome, via England and Germany, and will leave by plane about 21st September.

イギリスには、九月二十五日より十日間ぐらい滞在<7.> _____ 予定で<8.> _____。何とぞ私同様に思し召してお世話<9.> _____ ますように、心から<10.> _____ 願い _____。

Igrisu ni wa, kugatsu nijūgo-nichi yori† tōkakan-gurai taizai <7.> I _____ yotei <8.> DE G _____ . Nanitozo watakushi dōyō ni oboshimeshite o-sewa <9.> K _____

* A depreciatory suffix indicating the plural or "people such as _____, The likes of _____". Cf. the neutral suffix たち *tachi* and the honorific suffix 方 *gata*: 私達 *watashi-tachi*

(i) 私ども *watakushi-domo* あなた達 *anata-tachi*
あなた方 *anata-gata*

(ii) あの者ども *ano mono-domo* あの人達 *ano-hito-tachi*
あの方々 *ano kata-gata*

† A literary, formal equivalent for colloquial から *kara* "from".

-masu yō ni, kokoro kara <10.> _____ -NEGAI M _____ .

He expects to stay in England for about ten days from the 25th September. I ask you most earnestly to be good enough to help by thinking of him as you would myself.

高橋は、千葉教育大学の教授で、美学美術史の方ではかなりの仕事を<11.> _____ <12.> _____。ロンドンでも美術館をはじめその関係の視察をする予定で<13.> _____。小生の名刺を持って<14.> _____ と<15.> _____ からよろしく<16.> _____ 願い _____。本当に勝手なお<17.> _____ で恐縮で<18.> _____ が、くれぐれもよろしくお願い申し上げます。

Takahashi wa, Chiba Kyōiku Daigaku no kyōju de, bigaku bijutsushi no hō de wa kanari no shigoto o <11.> I _____ <12.> O _____ . Rondon de mo bijutsukan o hajime sono kankei no shisatsu o suru yotei <13.> DE G _____ . Shōsei no meishi o motte <14.> O- _____ to <15.> Z _____ kara yoroshiku <16.> _____ -NEGAI M _____ . Hontō ni katte na <17.> _____ -NEGAI de kyōshuku <18.> DE G _____ ga, kuregure mo yoroshiku o-negai mōshiagemasu.

Takahashi is a professor at Chiba Education University, and has done quite a bit of work in the field of aesthetics and the history of fine art. He plans to look over, in London as elsewhere, art museums and other such places. Since I expect that he will be calling on you with my card, I (would like to) ask you for your help. I am reluctant to make such a truly selfish request, but I do ask you most earnestly for your help.

ヨーロッパでまた <19.> _____ 目に _____ ことを
楽しみに <20.> _____ <21.> _____。

Yōroppa de mata <19.> _____ **-ME NI K** _____ **koto**
o tanoshimi ni <20.> **I** _____ <21.> **O** _____。

I am looking forward with pleasure to being able to see you
again, in Europe.

末筆で <22.> _____ が中田さまの <23.> _____ によ
ろしくお伝え <24.> _____ <25.> _____。

Mappitsu <22.> **DE G** _____ **ga Nakata-sama no**
<23.> **MINA-S** _____ **ni yoroshiku o-tsutae** <24.> **K** _____
<25.> **-M** _____。

Last (but not least), please pass on my regards to all the
Nakatas.

敬具

Keigu,

With respect,

八月十六日

Hachigatsu jūroku-nichi

16th August

古川義行

Furukawa Yoshiyuki

Yoshiyuki Furukawa

B. C. ロバート様

B. C. Roberts-sama

Mr. B. C. Roberts

Answer Key

1. いただき **ITADAKI** (Dp 2 もらい **morai**) page 78
2. ございました **GOZAIMASHITA** (Df 2 ございます **gozaimasu**) page 117
3. いたし **ITASHI** (Dp 2 し- **shi-**) page 117
4. いたし **ITASHI** (Dp 2 し- **shi-**) page 117
5. 参る **MAIRU** (Dp 2 いく **iku**) page 78
6. いたし **ITASHI** (Dp 2 し- **shi-**) page 117
7. いたす **ITASU** (Dp 2 する **suru**) page 117
8. (で) ございます **(DE) GOZAIMASU** (Df 2 です **desu**)
page 117
9. ください **KUDASAI** (H2 くださる/くれる **kudasaru/kureru**) page 54
10. お(願い)申し上げます **O(-NEGAI) MŌSHIAGEMASU**
(Df 2 願います **negaimasu**) page 116
11. いたして **ITASHITE** (Dp 2 して **shite**) page 78
12. おります **ORIMASU** (Df 2 います **imasu**) page 117
13. (で) ございます **(DE) GOZAIMASU** (Df 2 です **desu**)
page 117
14. お伺いする **O-UKAGAI SURU** (Dp 2 たずねる **tazuneru**)
page 83
15. 存じます **ZONJIMASU** (Df 2 思います **omoimasu**)
page 116
16. お(願い)申し上げます **O(-NEGAI) MŌSHIAGEMASU**
(Df 2 願います **negaimasu**) page 116
17. お(願い) **O(-NEGAI)** (P 2 願い **negai**) page 31
18. (で) ございます **(DE) GOZAIMASU** (Df 2 です **desu**)
page 117
19. お(目に)かかれる **O(-ME NI) KAKARERU** (Dp 2 あげる **aeru**) page 83

20. いたして **ITASHITE** (Dp 2 して **shite**) page 78
 21. おります **ORIMASU** (Df 2 います **imasu**) page 117
 22. (で) ございます (**DE**) **GOZAIMASU** (Df 2 です **desu**)
 page 117
 23. (皆) さま (**MINA**)-**SAMA** (P 3 皆さん **mina-san**) page 131
 24. ください **KUDASAI** (H 2 ください **kudasai**) page 131
 25. ませ **MASE** (H 2 ください **kudasai**) page 115, pages
 134-135

Practice Text 2

Letter from a research student, aged about 25, to an older man.

拝復

Haifuku,

In respectful reply,

<1.> _____ 便りありがとうございました。研究所の方へご連絡くださいましたにもかかわらず御用をお足しになれませんでしたこと遺憾に <2.> _____。

<3.> _____、調査と個人研究に重点を置いて

<4.> _____ ため、正規の研究所員では

<5.> _____。つきまして、事務局庶務課に、下山恵子

という人があります。この前 <6.> _____ 紹介 _____

女性です。その方に <7.> _____ 用件をお話くだされば、

早速伝言してくれます。

<1.> _____ -**TAYORI arigatō gozaimashita. Kenkyūjo no hō e go-renraku kudasaimashita ni mo kakawarazu go-yō o o-tashi ni naremasen deshita koto ikan ni** <2.> **Z** _____.

<3.> **W** _____, **chōsa to kojīn kenkyū ni jūten**

o oite <4.> **O** _____ **tame, seiki no kenkyūshoin**